

TANIYAMA **MAF**

多翼送風機

MULTI BLADE FAN



株式会社 **タニヤマ**

MAF 多翼送風機の構造と特長

構造

タニヤマ多翼送風機は、堅牢な構造で、吸込空気が一様に羽根車に入り、かつ、羽根車から吐出された空気が、効率よく吐出口に導かれるように滑らかな渦巻状に成形され、渦流や圧力の脈動を極力防止するよう設計されています。

- (イ) ケーシングは十分な板厚の鋼板製とし、変形、振動、接合部からの漏洩等が生じないように溶接構造とし、形鋼により補強し、所要の負荷に耐えることは勿論、振動および音響の発生を防止し、据付ならびに運転上の支障をきたさないよう十分な剛性を保持しております。
- (ロ) 羽根車は半径方向に浅く、軸方向に長い前曲した数十枚の羽根をもち、両端は側板および本板に鋸締してあります。側板および本板は、完全な円形に仕上げ、羽根車ボスと本板は鋸締により、側板とは数本の控えボルトにより固定され強固な構造となっております。

- (ハ) 軸受は国産品中、最高級のローラまたはボールベアリングを使用し、グリース潤滑によって保守を容易にするとともに、耐用年数、温度状況、使用ガス体等に対して十分に考慮を払い、円滑な運転と耐久性を維持するようにしてあります。
- (ニ) 軸には炭素鋼鋼材または特殊鋼材を用い、研磨仕上げを施して精度を保つことは勿論、充分の強度を有しております。

特長

本送風機の特長は、低圧の送風用として水柱98～980Pa程度において最も適しております。

- (イ) 他の遠心式送風機に比較して同一容量に対する大きさ（呼び番号）は最も小さく、据付占有スペースが小さくて済みます。
- (ロ) 同一風圧に対しては、周速が最も小さく、従って低騒音であります。
- (ハ) 静圧曲線が緩やかなため風量変動に対し風圧の変化が少なく、多数の口から給排気している場合は、その一部を閉鎖しても他におよぼす影響が少なくて済みます。

MAF 多翼送風機の特性と標準容量範囲

図はMAF多翼送風機の代表的な特性曲線です。

図において静圧曲線の $P_1 \sim P_4$ までの領域は、一般に最もよく使用される標準容量範囲（図Sの範囲）で、各大きさ毎の容量図に示すとおりであり、この範囲内を使用されることが有利です。

なお、図に示す静圧曲線の $P_2 \sim P_3$ までの領域は、性能上最も好ましい範囲で、各呼び番号に対して使用領域の重複しない範囲です。

この領域は効率最高、騒音最低で、かつ、静圧曲線は右下りの安定勾配を示しますから、できる限りこの範囲内（図Oの範囲）で送風機の大きさを選定されることをご推奨いたします。

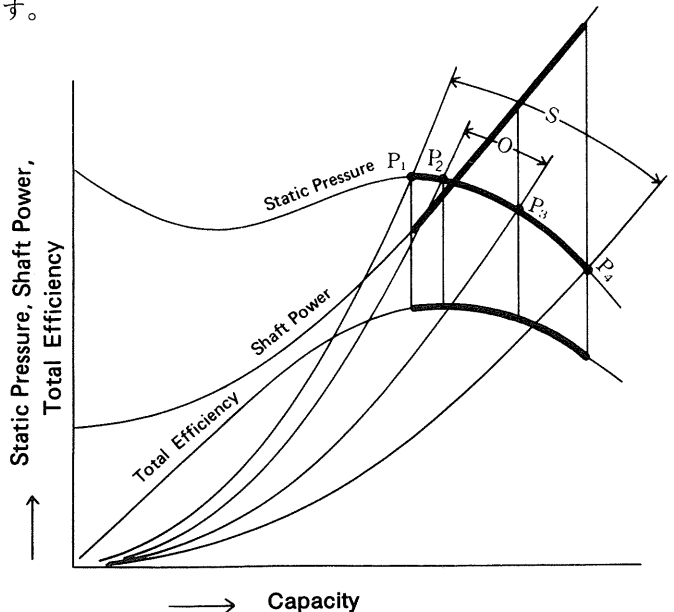

MAF 多翼送風機の特性と標準容量範囲の説明図
 Characteristics and Standard Capacity Range of
 MAF Multi-Blade Fan

Structure and features of MAF multiblade fan

Structure

TANIYAMA MAF multiblade fan is designed in stout structure, and in the way that suction air flows into the fans uniformly and air discharged from the fans is efficiently drawn to the discharge outlet in smooth scroll, minimizing vortex flow and pulsation of pressure.

- (a) The casing is made of steel plate with sufficient plate thickness, with welding structure to prevent deformation, vibration and leak from the joint parts, and is reinforced with shape steels to hold sufficient rigidity in order to withstand specified load, prevent generation of vibration and noise and not to cause trouble in installation and operation.
- (b) The impeller has 40~64 blades which are short radially and long axially. Both ends of the blades are riveted to the side plate and main plate. The side plate and the main plate are finished to complete round.
The impeller boss and the main plate are riveted to the side plate with several stay bolts, obtaining solid structure.
- (c) Bearings are highest grade roller or ball bearings.
Maintenance is made easy by grease lubrication. Smooth running and long durability are assured, taking durability, temperature condition and gas to be used into full consideration.
- (d) The shaft is made of carbon steel or special steel in grinding finish, assuring high precision and strength.



Features

THE MAF Multiblade Fan is used most suitably in water head approx. 98~980Pa, as low pressure blowing.

- (a) Size (nominal number) in the same capacity is the smallest of any others of other centrifugal fans, enabling compact installation space.
- (b) Peripheral speed in the same air pressure is the lowest of any others, enabling low noise.
- (c) Gradual static pressure curve minimizes change of air pressure in change of air volume; therefore, in discharging from several openings, effect is minor when some of the openings are closed.

Characteristics and standard capacity range of MAF multiblade fan

The figure shows typical characteristic curve of MAF multiblade fan.

The portion P1 ~ P4 of static pressure curve in the figure are the standard capacity range (range S) most frequently used generally, as shown in the capacity chart of each size.

Use in this range is favorable.

The portion P2 ~ P3 of the static pressure curve shown in the figure are the most favorable zone where use field to each nominal number is not duplicated.

P2~P3 fields have the highest efficiency and the lowest noise, and show right lowering stable gradient of the static pressure curve. Selecting stages of the fan in this range (range O) is commendable.

送風機のご照会について

送風機のご照会に際しては、下記の事項についてお知らせ願います。

1 空気量

原則として、標準吸込状態における空気量 m^3/min 又は m^3/hr をご指示下さるようお願いいたします。使用状態における空気量をご指示の場合は、使用状態における取扱気体の比重、および湿度をお知らせ下さい。

注：標準吸込状態とは温度 $20^{\circ}C$ 、絶対圧 $101.3kPa$ 、相対湿度 65% の湿り空気を吸い込む状態をいい、この状態における空気 $1m^3$ の重量は $1.20kg$ とみなす。(JIS B8330による)

2 送風機静圧または全圧

標準吸込状態における静圧、または、使用状態における静圧。

3 取扱気体の種類

空気または他のガス。他のガス体であればその組成および比重(空気に対する)。

4 使用温度

吸込温度 $^{\circ}C$

5 用途

換気(送風、排気)、冷暖房のダクト通風、乾燥、冷却、ダスト混入の有無等。

6 駆動形式

Vベルト駆動、直結、その他。

7 電動機

形式、出力、極数、電圧、メーカー、その他。

8 設置場所の周波数

60 ヘルツまたは 50 ヘルツ。

9 空気吐出方向と回転方向

10 分割形式

大形送風機は、搬入、据付および保守等を簡単にするために、ご要求によりケーシングを2分割もしくは3分割できるようにいたします。ただし、呼び番号7以下のものは原則として分割いたしません。

11 所要台数

12 運転時間

24時間連続運転か、1日何時間運転か。

13 各システムについてのご相談

- (1) 省エネ対策システム
- (2) 騒音対策システム
- (3) メンテナンスシステム
- (4) 制御システム

14 その他特殊用途の送風機についてもご相談ください。

INQUIRIES IN OUR FANS

Please let us have the following information when inquiring of our fans.

1 Gas/air Volume

As a general rule please let us have your information of gas/air volume m^3/min or m^3/hr under the normal inlet condition.

When you advise us the gas/air volume in a condition of your use, please inform us of the specific gravity of gas as well as of its humidity.

Note: The normal inlet condition is temperature $20^{\circ}C$, absolute pressure $101.3kPa$, humid air of relative humidity 65% .

The weight of air $1m^3$ under the above condition is regarded as $1.20kg$ (JIS B8330)

2 Static pressure or total pressure of fans

Static pressure under the normal inlet condition or static pressure in use.

3 Types of gases

Air or other gases. In case of other gases, the components and specific gravity (against air).

4 Temperature in use

Inlet temperature $^{\circ}C$ (degree centigrade/Celsius)

5 Application

Ventilation (supply, exhaust), air duct draft in air conditioning, drying, cooling, inspection of dust or dirt intrusion, etc.

6 Types of driving

V-belt driving, direct coupling and others.

7 Motors

Type, power, number of poles, voltage, maker and others.

8 Frequency of the location installed

60 Hz or 50 Hz.

9 Air/gas discharge position and direction of rotation

10 Types of division

Large size fans can be divided into 2 or 3 in their casing according to your request so as to make them easy to forward and to install and for maintenance.

However, we can not accept your request for fan size 7 or less as a general rule.

11 Units in need

12 Operation time

24-hour continuous running or several hours per day.

13 Consultation on each system

- (1) System for saving the natural resources
- (2) System for noise pollution
- (3) Maintenance system
- (4) Control system

14 We await your inquiries as to the fans for special purposes.

遠心送風機の回転方向と吐出方向

遠心送風機の吐出方向は下図に示すとおりで、すべてプーリ側（直結駆動式の場合は電動機側）よりみた吐出方向を表わしております。回転方向は同様にプーリ側よりみて右（時計回転）の場合を右回転と呼び、左（反時計回転）の場合を左回転と呼びます。

ご注文の際は、下図のなかから選定されご指示下さい。

DIRECTION OF ROTATION AND DISCHARGE POSITIONS OF CENTRIFUGAL FAN

Discharge positions of the centrifugal fan is shown in the below figures, indication discharge positions viewed from the pulley side (motor side in case of the direct drive type).

As for direction of rotation, rightward (clockwise) rotation in viewing from the pulley side is called right rotation, and left (counterclockwise) rotation is called left rotation.

In ordering, please select among the belows.

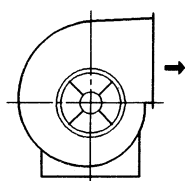

R1
右回転上部水平吐出
CLOCKWISE
TOP HORIZONTAL

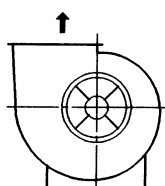

R2
右回転上部垂直吐出
CLOCKWISE
UP BLAST

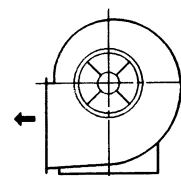

R3
右回転下部水平吐出
CLOCKWISE
BOTTOM HORIZONTAL

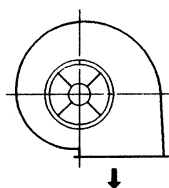

R4
右回転下部垂直吐出
CLOCKWISE
DOWN BLAST

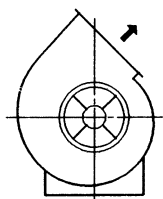

R5
右回転上部45°上向吐出
CLOCKWISE
TOP ANGULAR UP

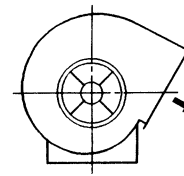

R6
右回転上部30°下向吐出
CLOCKWISE
TOP ANGULAR DOWN

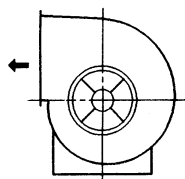

L1
左回転上部水平吐出
COUNTER-CLOCKWISE
TOP HORIZONTAL

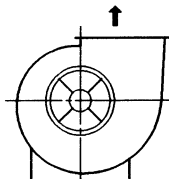

L2
左回転上部垂直吐出
COUNTER-CLOCKWISE
UP BLAST

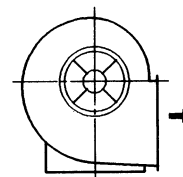

L3
左回転下部水平吐出
COUNTER-CLOCKWISE
BOTTOM HORIZONTAL

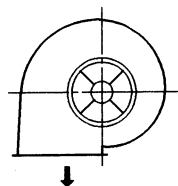

L4
左回転下部垂直吐出
COUNTER-CLOCKWISE
DOWN BLAST

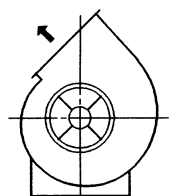

L5
左回転上部45°上向吐出
COUNTER-CLOCKWISE
TOP ANGULAR UP

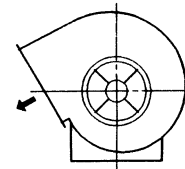

L6
左回転上部30°下向吐出
COUNTER-CLOCKWISE
TOP ANGULAR DOWN

形式 Type	摘 要	Description
S1	片吸込式 送風、還気、排気用としてもっとも広く使用されますが、第1軸受が送排気ガスに直接さらされるため、100℃を超える空気、または、直接水滴や塵埃が軸受にかかるような場合には使用しないよう注意して下さい。	Single Suction Type This type is most commonly used for supply, return and exhaust fan. The first bearing is exposed to gases. Therefore, this type should not be used in applications where gas temperatures exceed 100℃ or where the bearing may be in direct contact with water drips or dust.
S2	オーバーハングホイール形 ケーシングの外側に軸受を設け、保守、点検を容易にした構造をしており、特殊ガス、高温、高湿度、塵埃等を取扱う場合に使用します。	Overhang Wheel Type The bearing is placed outside the casing for ease of inspection and maintenance. This type exhibits excellent performance when used in special gas, heavy dust, or abnormally high temperature and humidity conditions.
S2-H	耐熱形 ボイラ、燃焼炉等の熱風を取扱うようなところに主として使用され、軸受は空冷式（空冷風車にて効率よく冷却）で保守、点検を容易にしており、300～400℃程度まで使用できます。	Heat-Resistant Type This type is often employed in a boiler, furnace, or others where hot blasts are involved. The bearing is air-cooled by a highly efficient radiation runner, resulting in easy maintenance and inspection. It can be used for temperatures of up to 400℃.
S6	電動機直動形 電動機軸端に直接羽根車を取付けたもので構造および取扱いが簡単で、据付スペースが小さく、保守、点検の必要は殆どありません。	Direct Drive Type The impeller is directly attached to the end of the motor shaft. The simple structure results in easy handling and virtually no inspection nor maintenance, are necessary.
D1	両吸込式 送風、還気、排気用として使用されますが軸受、Vプーリ、Vベルト等が送排気ガスに直接さらされるため、100℃を超える空気、または、直接水滴や塵埃がこれ等にかかるようなところには使用しないよう注意して下さい。	Double Suction Type This Type is for supply, return and exhaust fan. The V-pulley and V-belt are exposed to gases. Therefore, this type should not be used in applications where gas temperatures exceed 100℃ or where the V-pulley and V-belt may be in direct contact with water drips or dust.
D2	プーリ側軸延長形 主として、現地施工の大形空調機室内に取付けて用いられるもので、Vプーリが空調室の外側へ出るようプーリ側軸を延長し、駆動電動機を空調室外で使用するようにしたものです。	Pulley Shaft Extension Type This type is normally used in a large fan chamber and is site-installed. The pulley shaft is extended so that the pulley can be installed outside the fan chamber, allowing the drive motor to run outside.
D6	4点軸受カップリング形 空調室巾が特に大きく軸延長だけでは不安定なもの、または、大形の送風機の場合には、この4点軸受形を用いて運転状態の安定化をはかります。	Four-Point Bearing Coupling Type This drive type is used to stabilize operation when a large size fan is used or when a fan chamber is too large to allow for an extension of the pulley shaft.

形式 Type

摘要

Description

D7

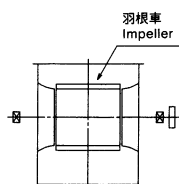

エアコン形

軸受は空調機等の壁面、または、適当な箇所に取付けられ比較的小形な送風機でパッケージ等に組込んでよく使用されております。

Air Conditioner Type

This type of drive is commonly used for a small-sized fan in package form. The bearing is attached onto the wall of an air conditioner or at another location.

D1-S

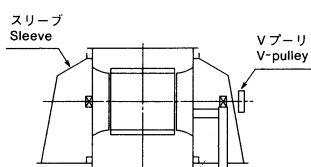

スリーブ付軸受内装形

D1形送風機の両側にスリーブを取付けたもので、現場据付工事が簡単になるようにしたものです。

Sleeve-Fitted Type

This is basically the D1 Type with sleeves on both sides. It is convenient for on-site installation.

D1-SM

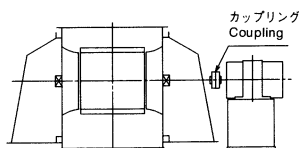

スリーブ付電動機直結形

電動機直結式のスリーブ送風機で、保守が容易で特に大容量の場合に好んで用いられます。

Sleeve-Fitted and Direct Drive Type

This direct drive system with sleeve on both sides is used when a large capacity is required. Its maintenance is easy.

D2-S

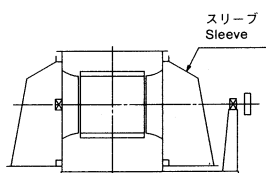

スリーブ付プーリ側軸延長形

D2形送風機の両側にスリーブを取付けたもので、小形、中形送風機に適しております。

Sleeve-Fitted and Pulley Shaft Extension Type

This is basically the D2 type with sleeves on both sides. It is often used with a small or medium-sized fan.

D3-S

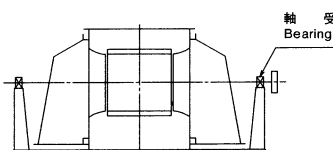

スリーブ付両側軸延長形

軸受を取扱空気に直接さらしてはいけない場合に用いますが、大形の場合は構造的に高価となるため、呼び番号は8番までとします。

Sleeve-Fitted and Both-End Shaft Extension Type

This type is used when direct contact of the bearings with air is prohibited. This type is available only in nominal size 8 or smaller sizes, as the larger sizes would be too costly to produce.

D3-SH

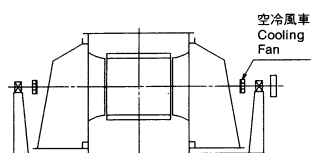

スリーブ付耐熱形

100℃を超える熱風を通す場合に用いるもので、放熱および冷却用の風車を取付けて軸受を保護するとともに、使用条件に応じてクリアランスの大きい(普通C₃級)特殊軸受を用います。大形の場合は、片吸込式耐熱形を使用した方が有利です。

Sleeve-Fitted Heat-Resistant Type

This type is used in applications where air temperature exceeding 100℃ is sent through the fan. A radiation runner for cooling is incorporated to protect the bearings. Usually, special bearings (normally class C₃) with a large clearance are used. For large size fans, the single suction heat-resistant type will be more advantageous.

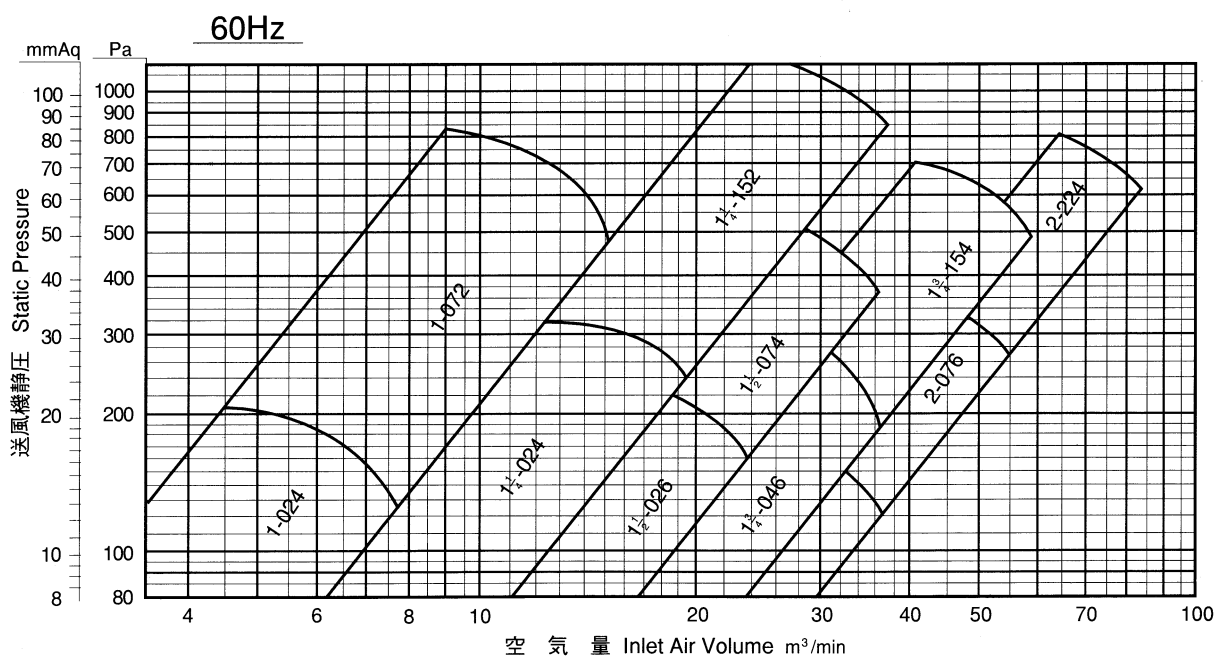
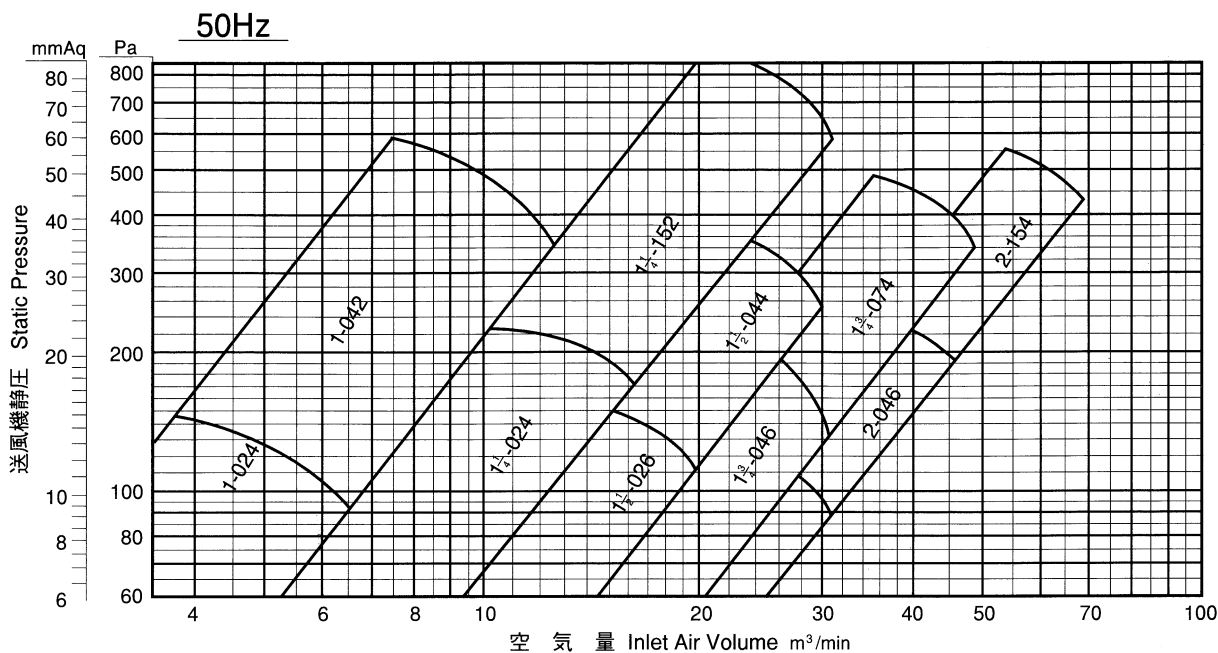

記号説明 Explanation of symbole

例: 1 ¹/₄ -152

- 152 : 電動機容量 (1.5kw2p) Motor output
- 1 ¹/₄ : 送風機呼び番号 Fan size

直動式 S6形 寸法表 DIRECT DRIVE TYPE DIMENSIONS

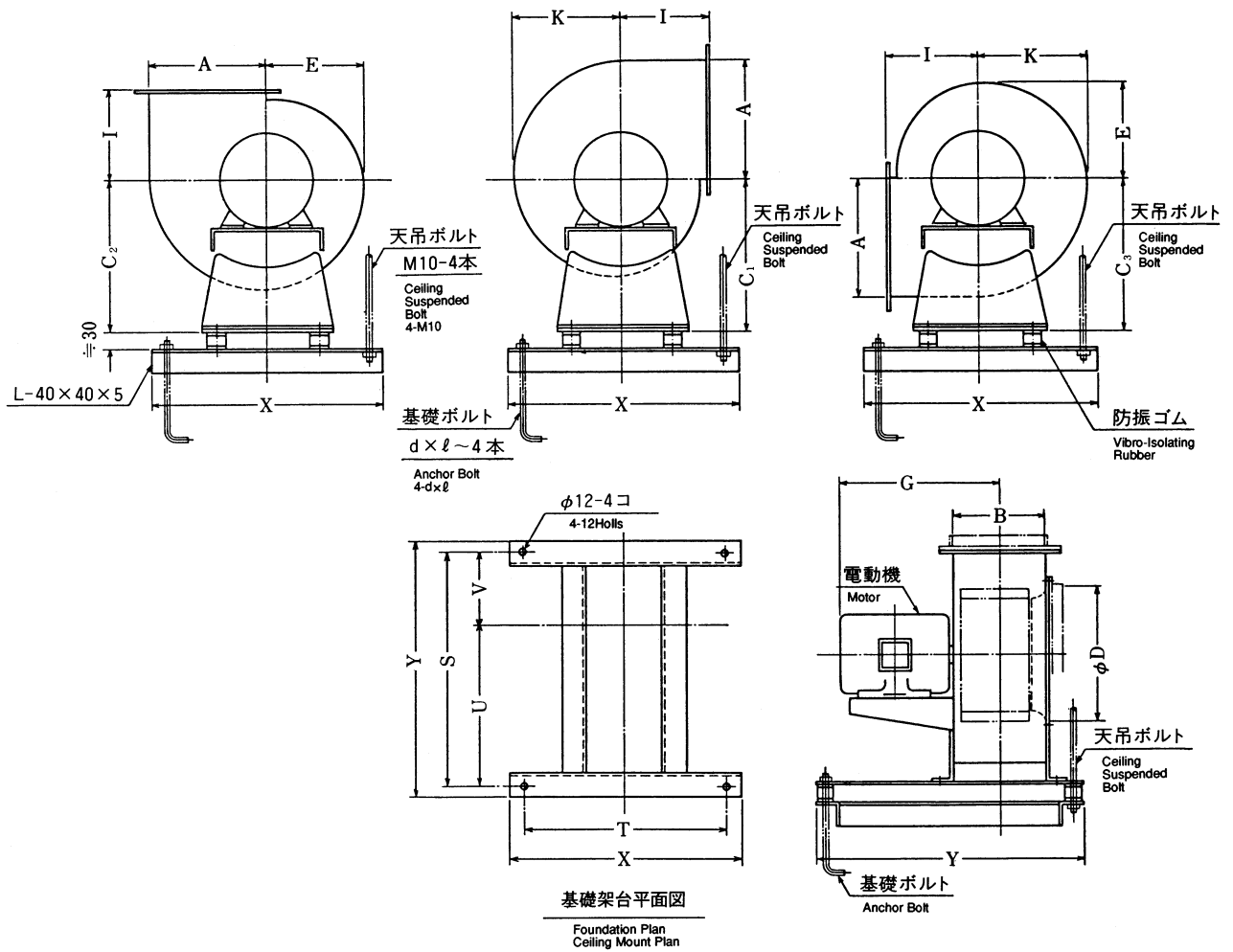

(mm)

呼び 番号 Fan Size	ケーシング Casing							芯高 Center Height			防振架台 Plan						基礎ボルト Anchor Bolt		山形鋼相フランジ Companion Flange	
	A	B	D	E	I	K	※G	C ₁	C ₂	C ₃	S	T	U	V	X	Y	d	ℓ	吐出	吸込
1	150	120	165	114	155	130	290	150	150	200	374	330	257	117	380	410	M10	160	L-25×25×3	L-20×20×1
1¼	190	150	203	143	155	163	350	200	200	240	374	330	257	117	380	410	M10	160	L-25×25×3	L-25×25×1
1½	228	180	242	171	180	195	320	230	230	280	434	410	282	152	460	470	M10	160	L-25×25×3	L-25×25×1
1¾	268	210	284	200	210	228	380	250	250	320	434	410	282	152	460	470	M10	160	L-25×25×3	L-25×25×1
2	300	240	335	228	250	260	430	310	310	375	470	460	282	182	500	500	M10	160	L-30×30×3	L-30×30×3

注1. 天吊ボルトは貴社にてご用意下さい。

2. ※印のついた寸法は、使用電動機により多少変更することがあります。

Notes: 1.Ceiling Suspension Bolts are excluded from our supply.

2.Subject to motor selection,dimensions marked ※ may vary.

特長

1. 振動、騒音は殆どなく、理想的なコンパクト送風機です。
2. 電動機直動式で軽量かつ取扱いが簡単です。
3. 据付スペースが小さく、保守点検の必要は殆どありません。

Features: 1.Ideally compact fan virtually free vibration and noise.

2.Direct drive type means simple handling and lightweight design.

3.Small space requirement. Virtually no need for check and maintenance.

MAF 1 Single Suction Type

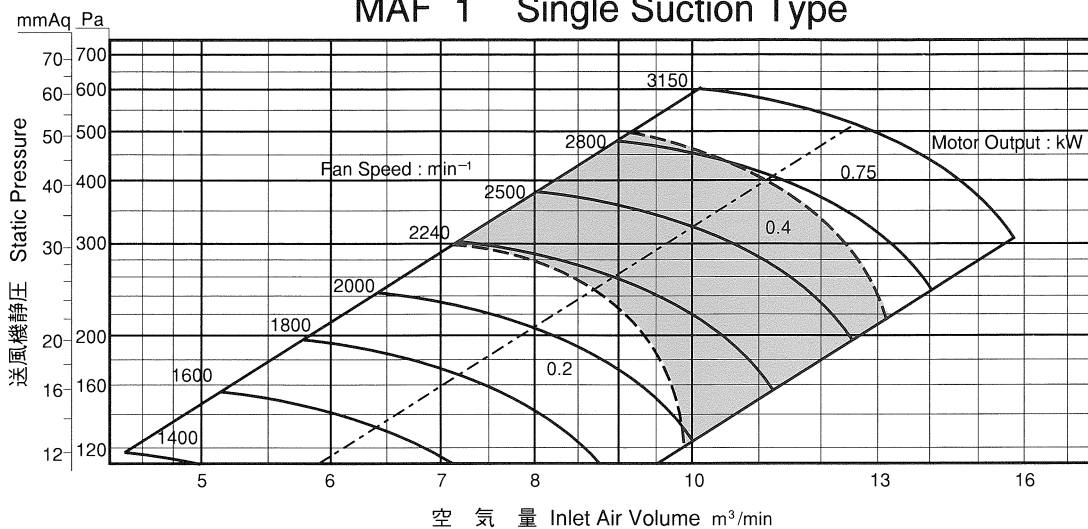

MAF 1¼ Single Suction Type

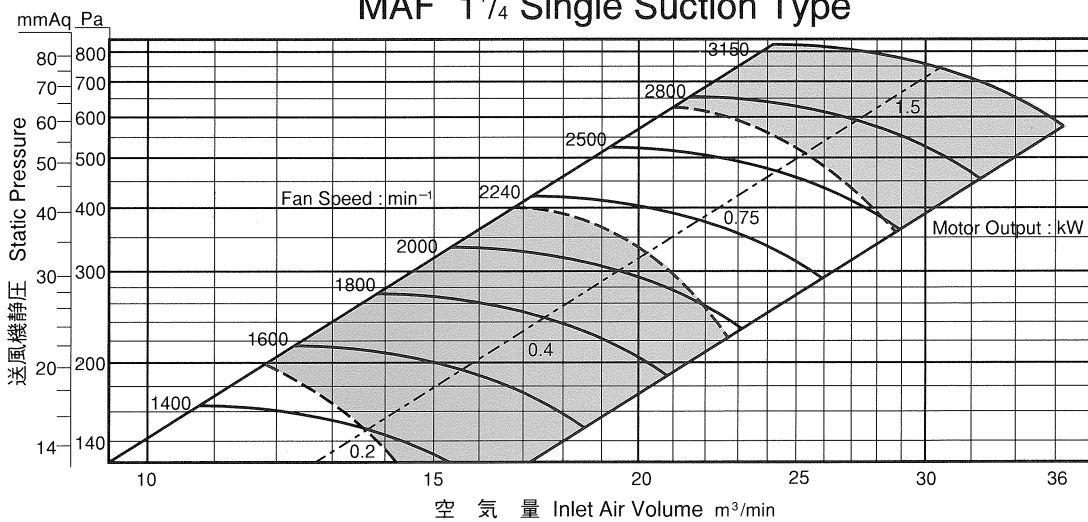

MAF 1½ Single Suction Type

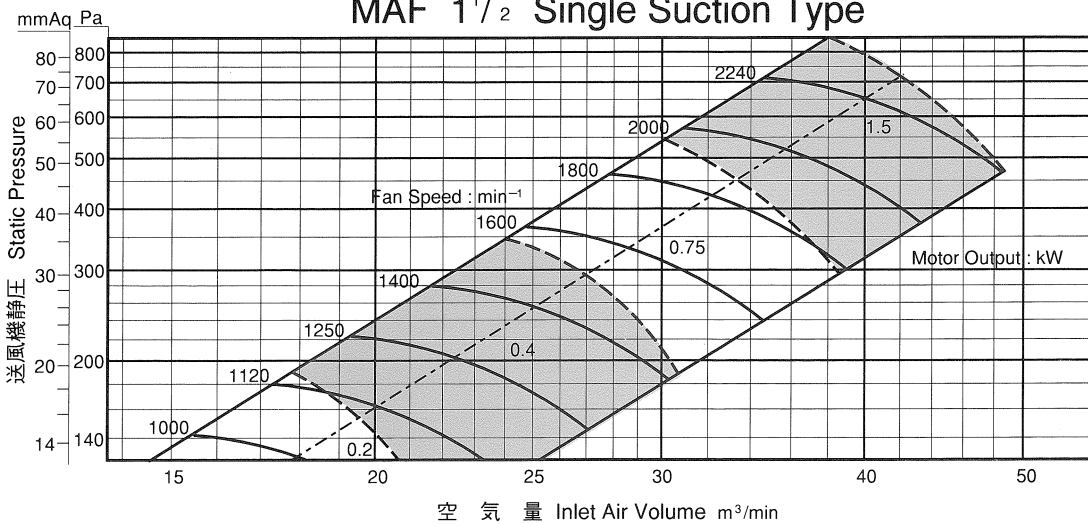

片吸込式容量図 SINGLE SUCTION TYPE CAPACITY CHART

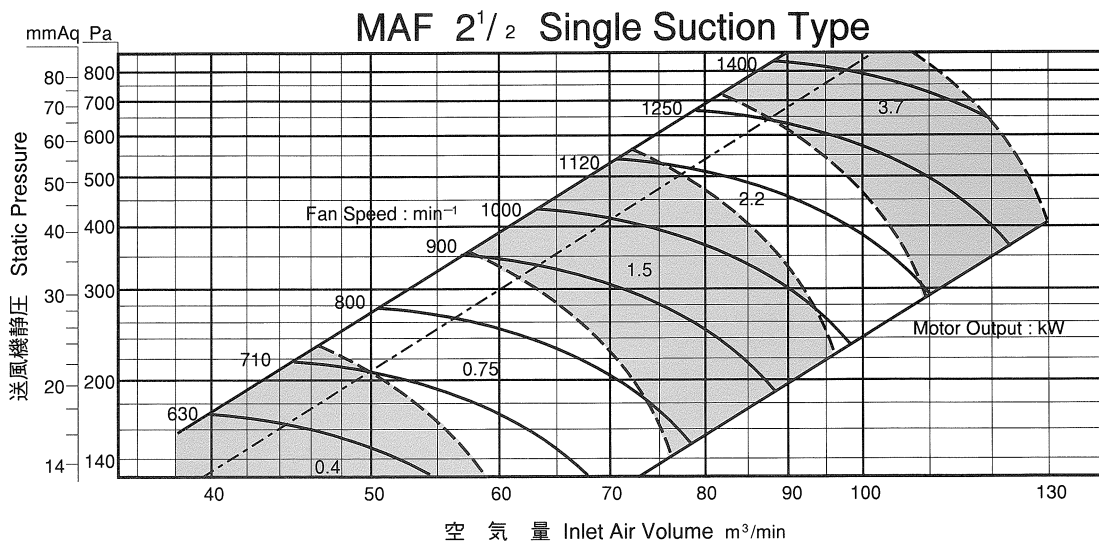
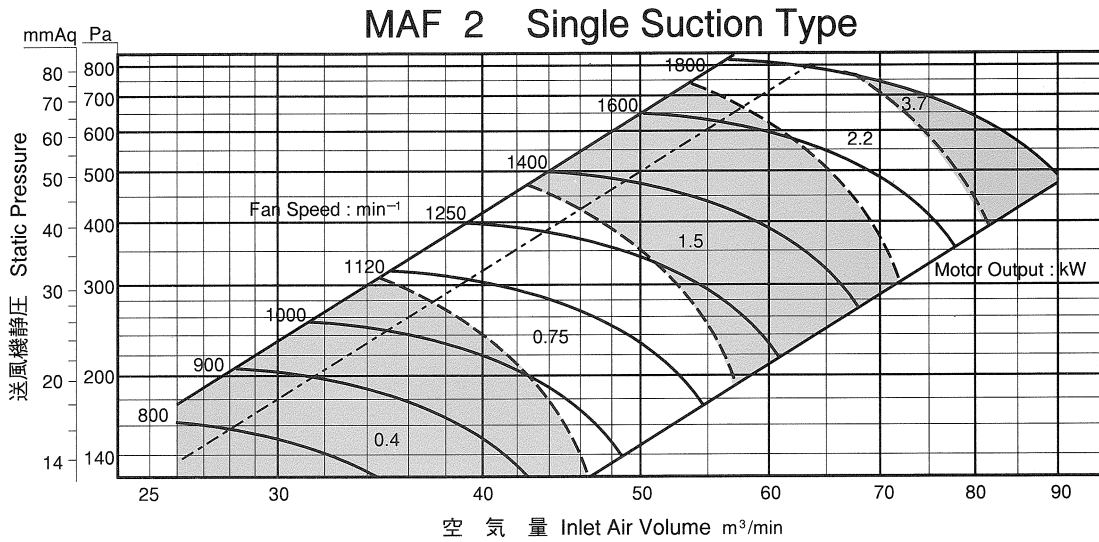
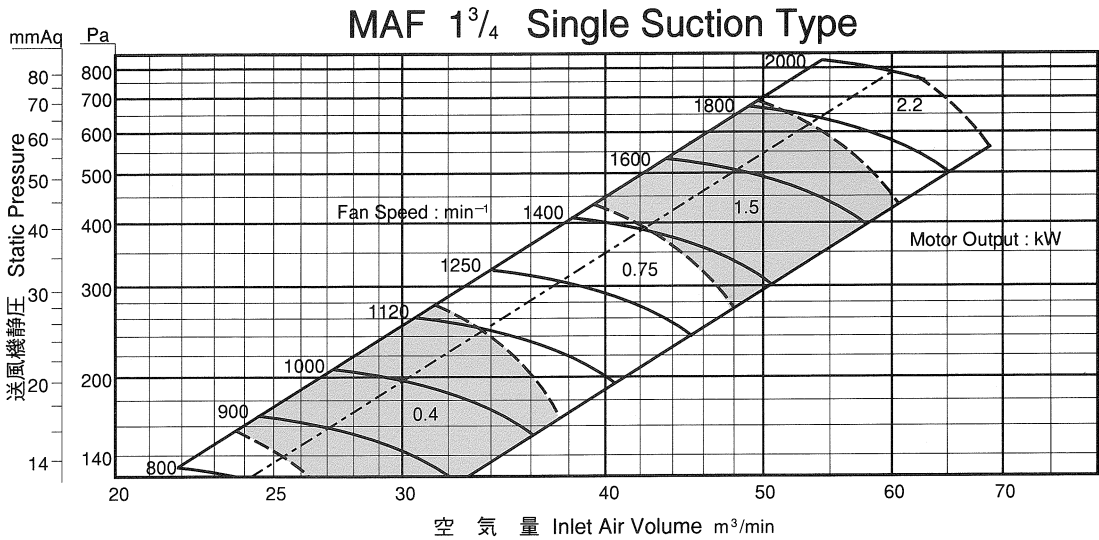

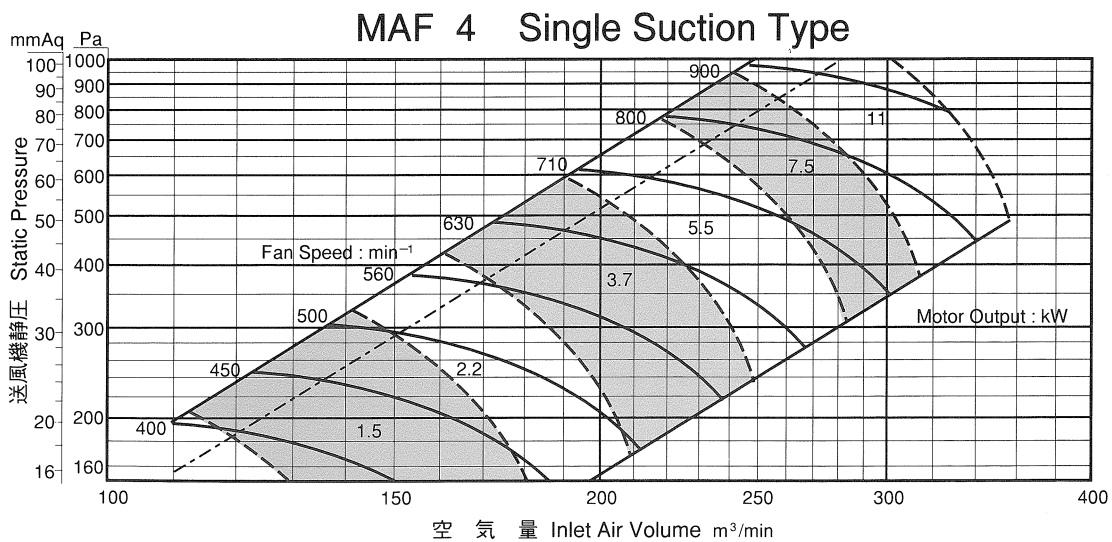
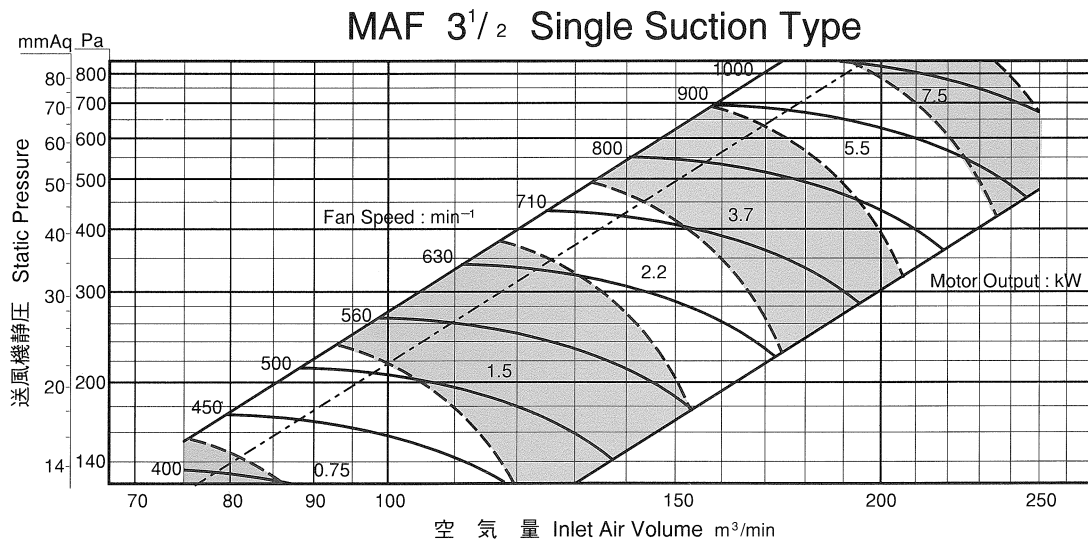
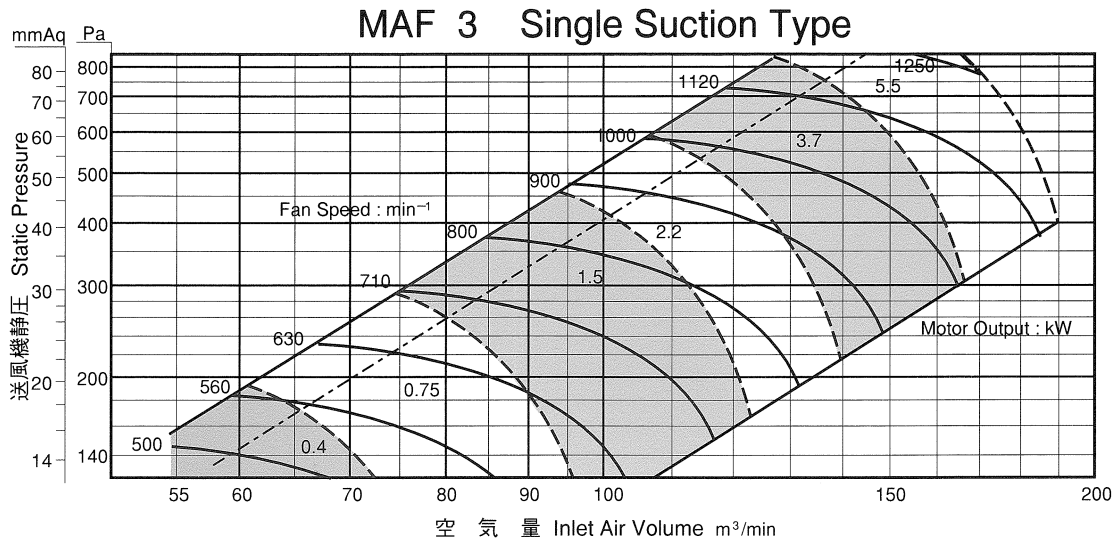

片吸込式容量図 SINGLE SUCTION TYPE CAPACITY CHART

MAF 4¹/₂ Single Suction Type

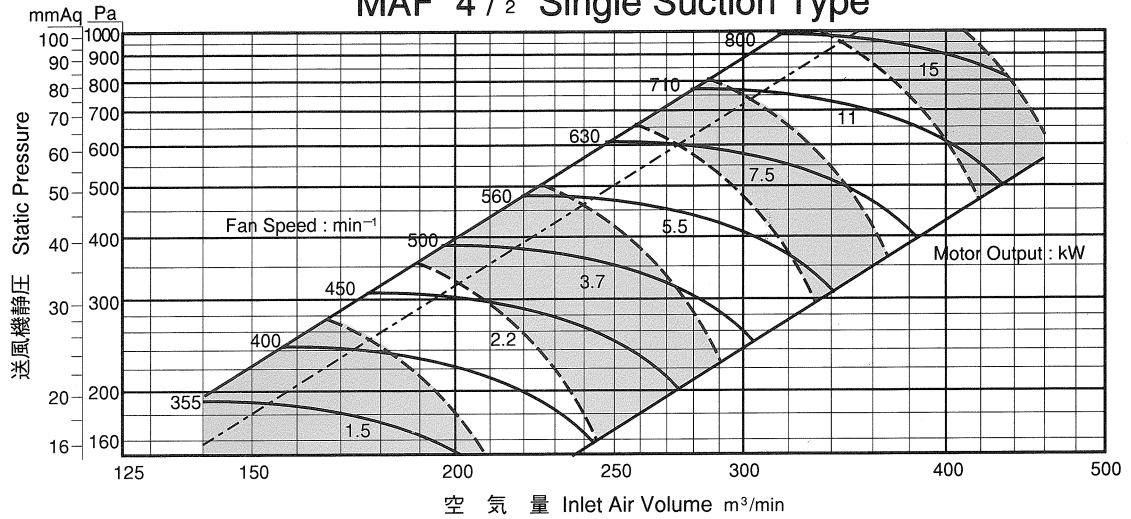

MAF 5 Single Suction Type

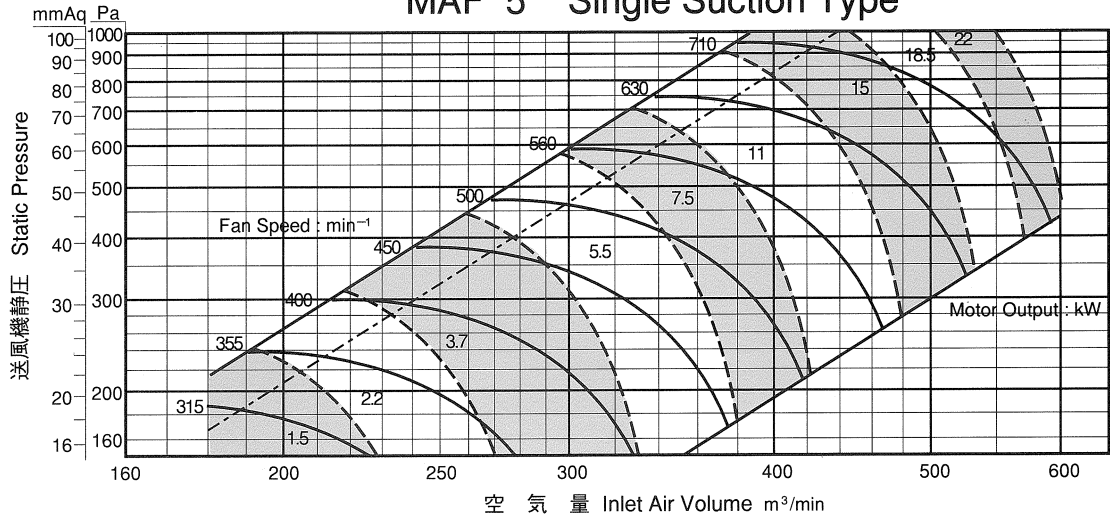

MAF 5¹/₂ Single Suction Type

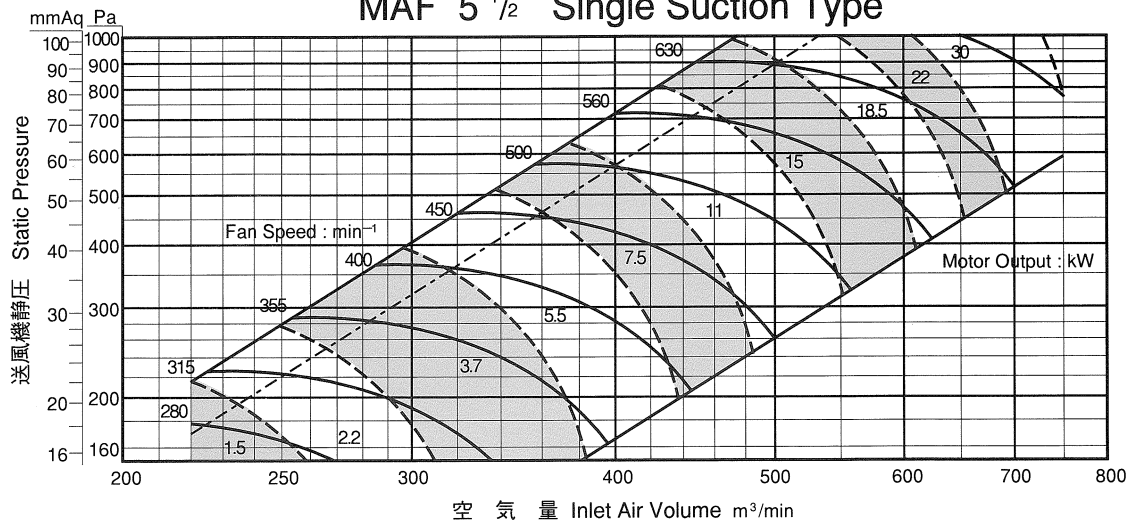

MAF 6 Single Suction Type

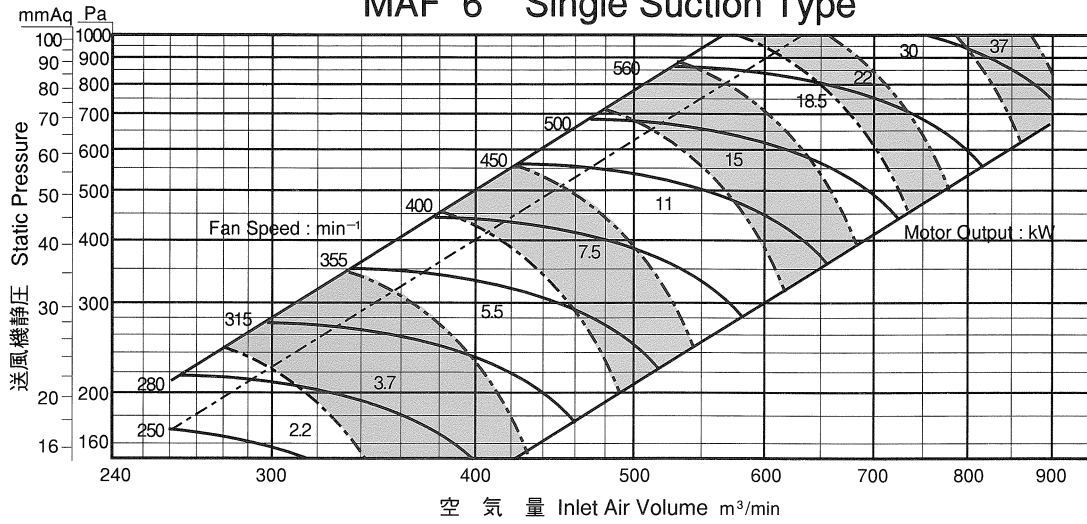

MAF 7 Single Suction Type

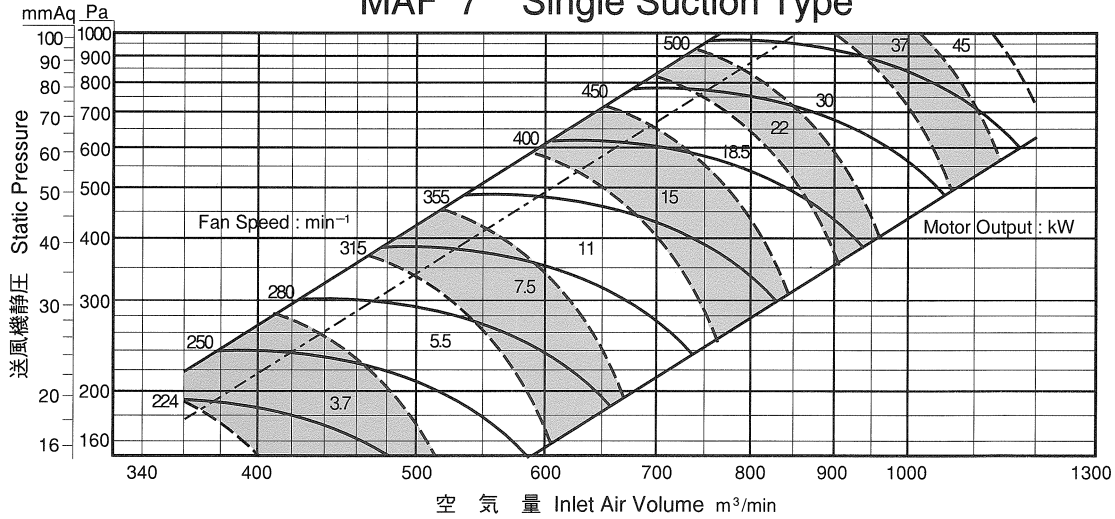

MAF 8 Single Suction Type

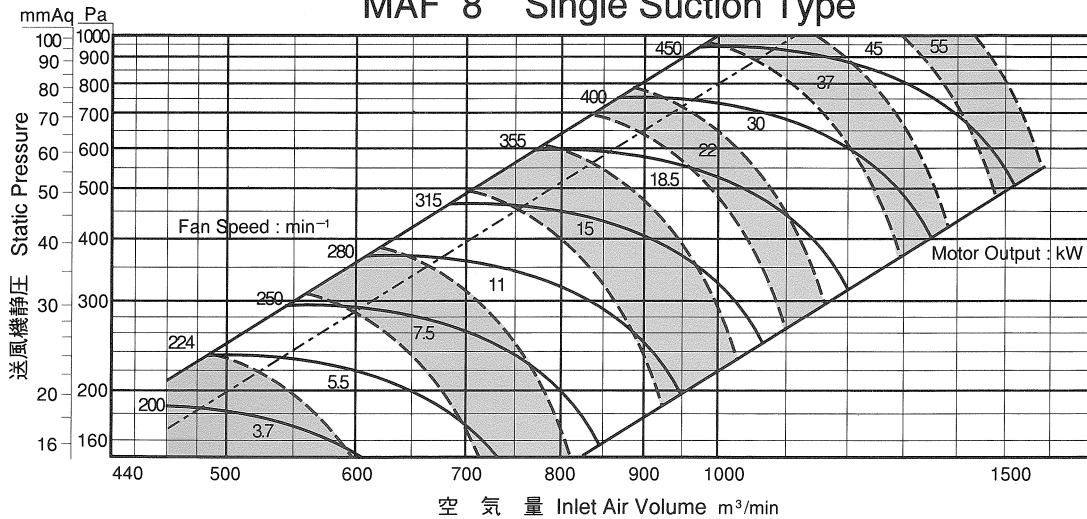

片吸込式容量図 SINGLE SUCTION TYPE CAPACITY CHART

MAF 9 Single Suction Type

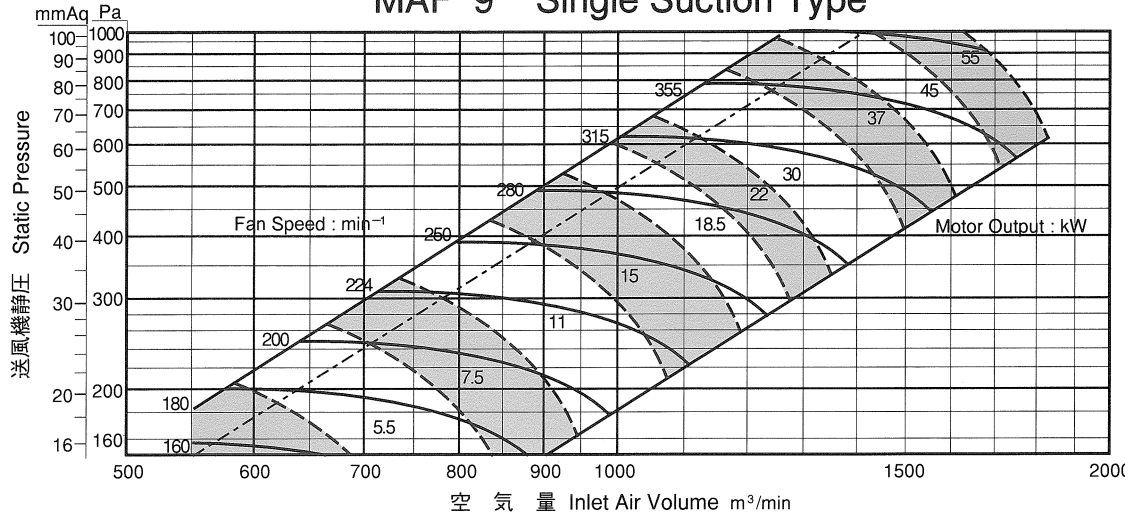

MAF 10 Single Suction Type

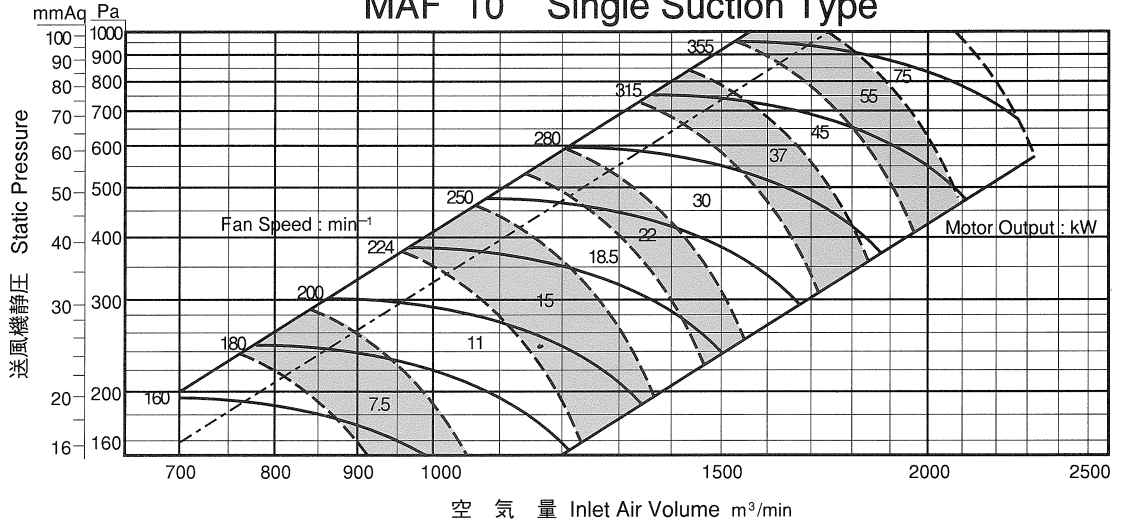

MAF 11 Single Suction Type

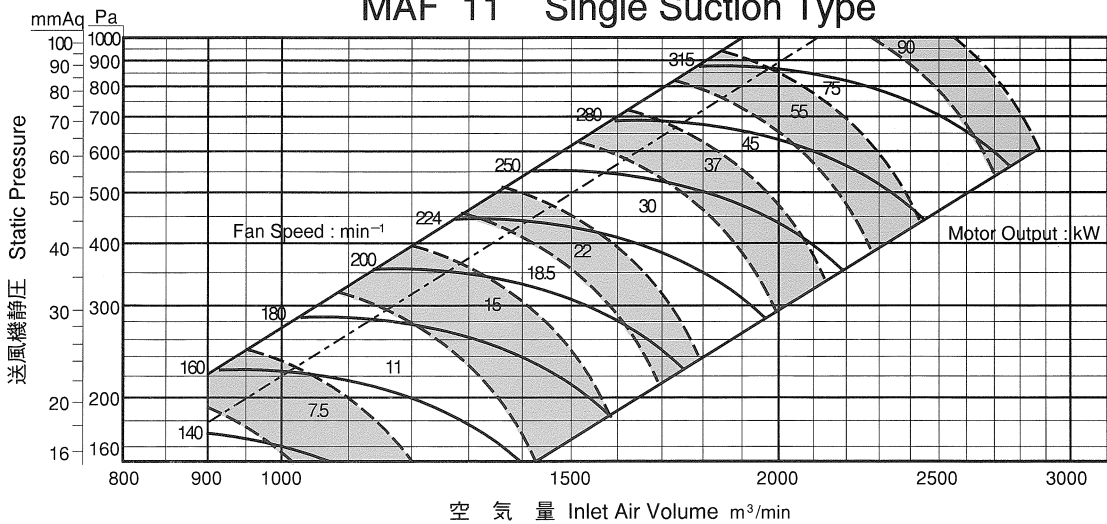

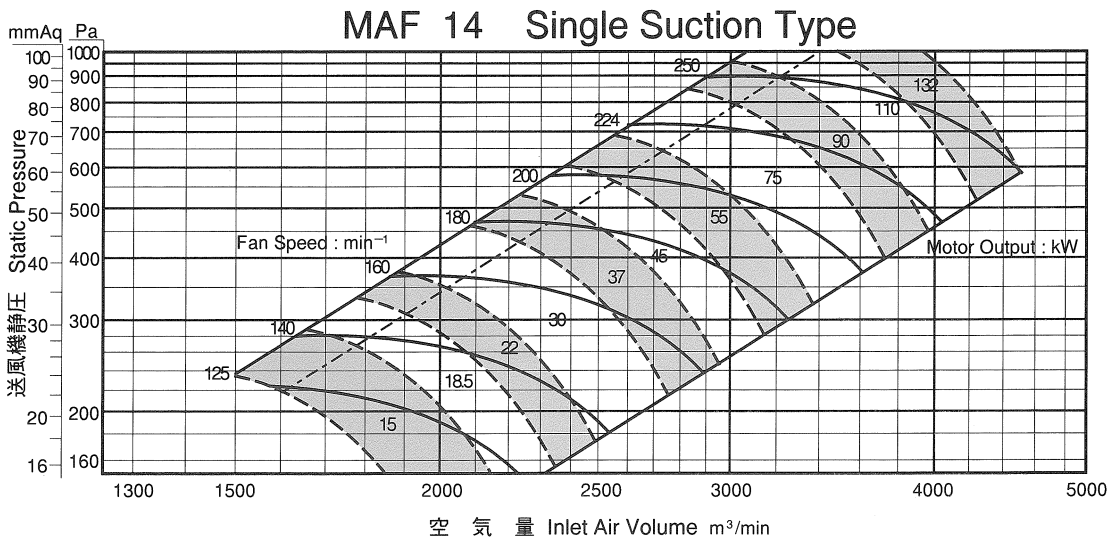
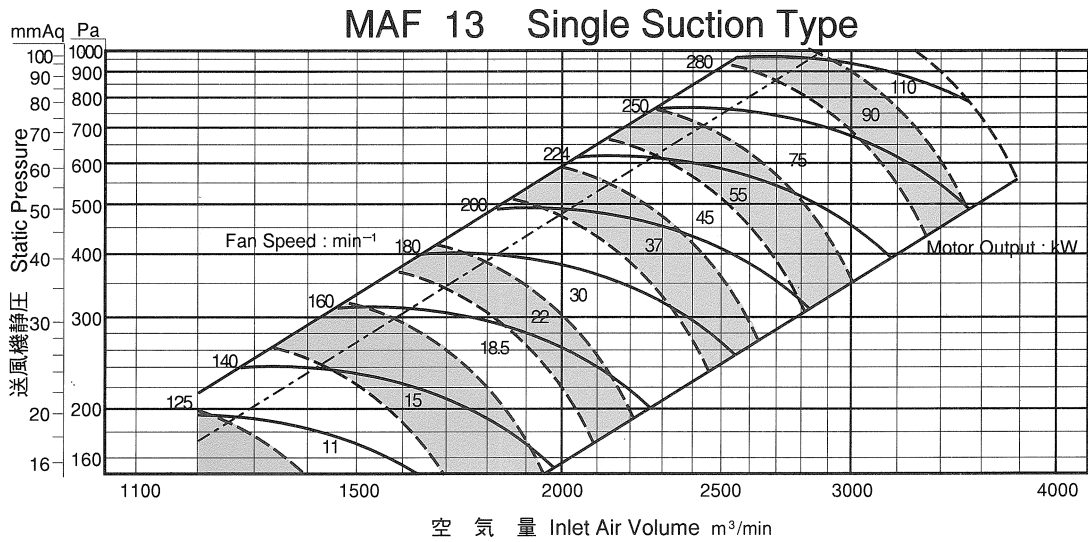
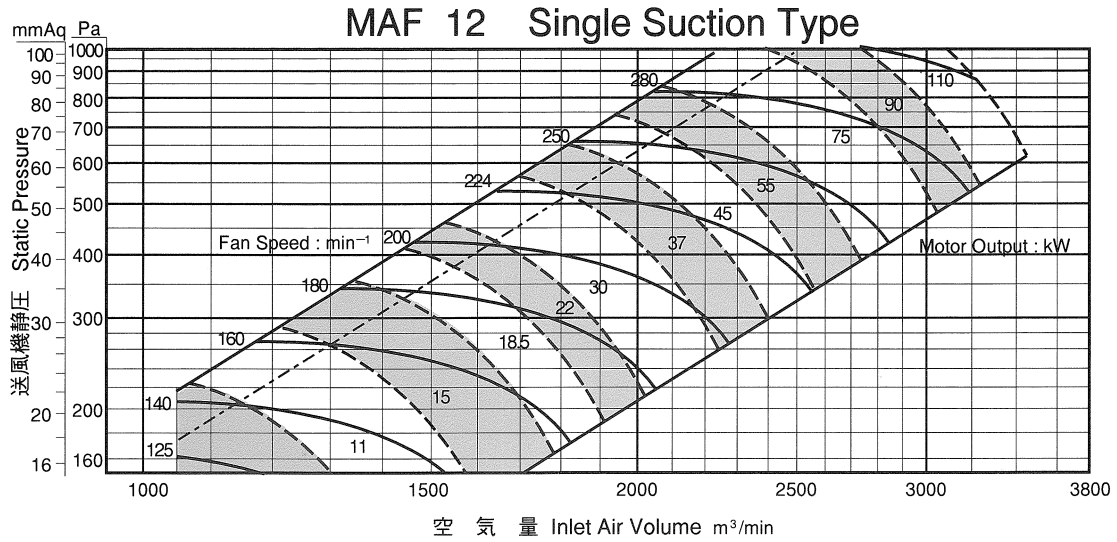

片吸込式容量図 SINGLE SUCTION TYPE CAPACITY CHART

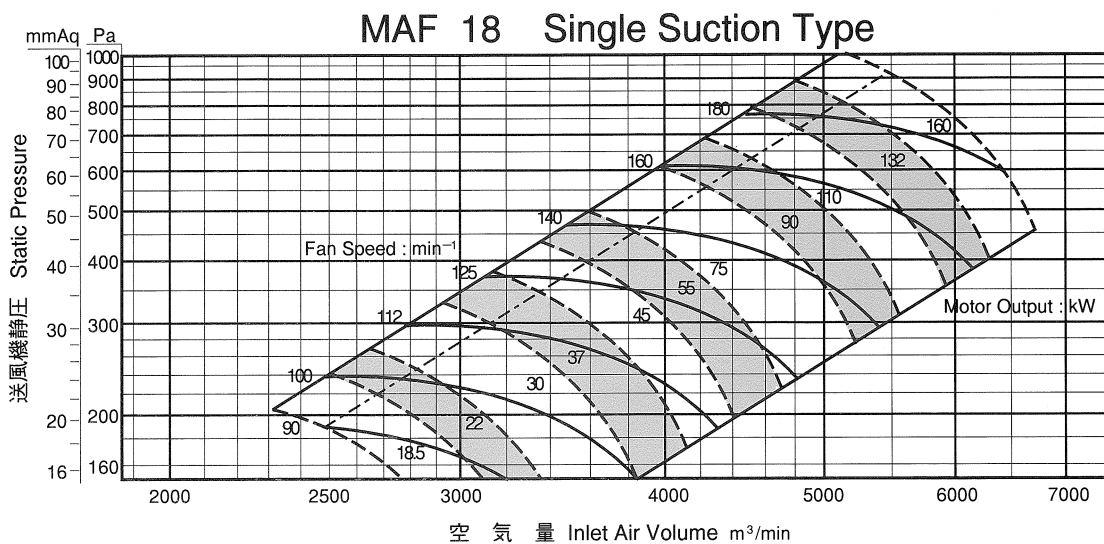
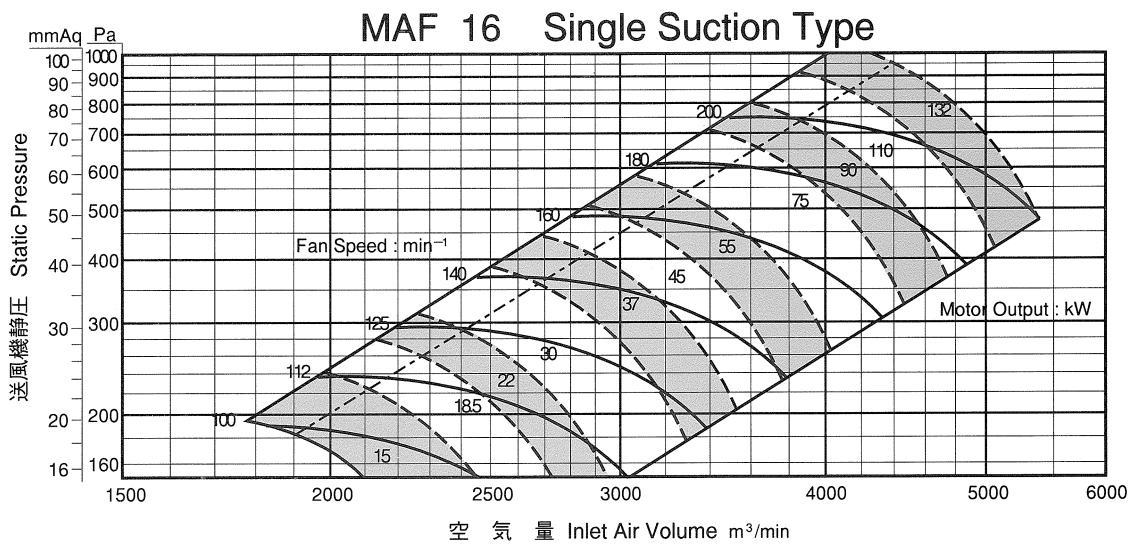
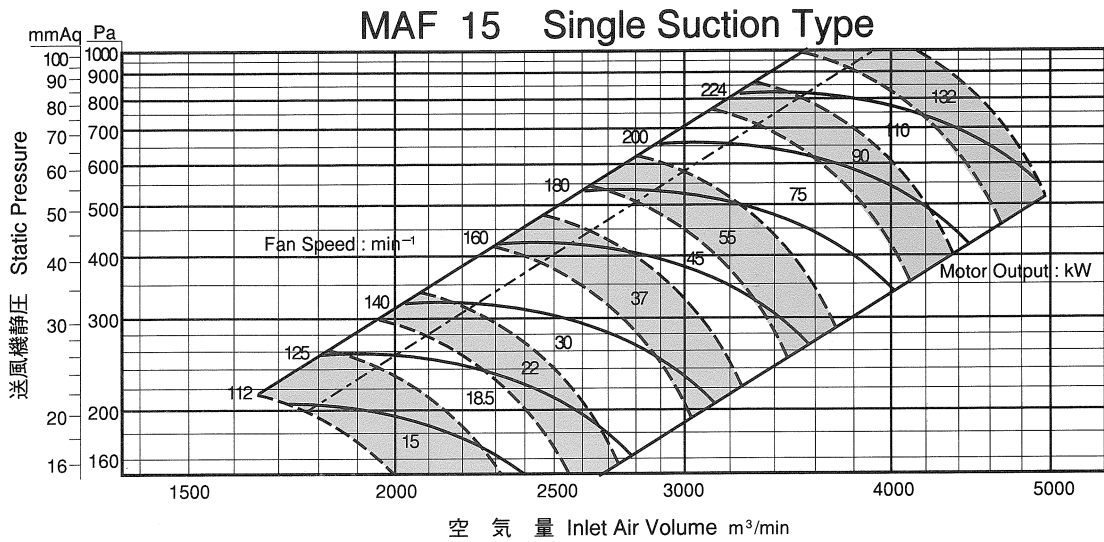

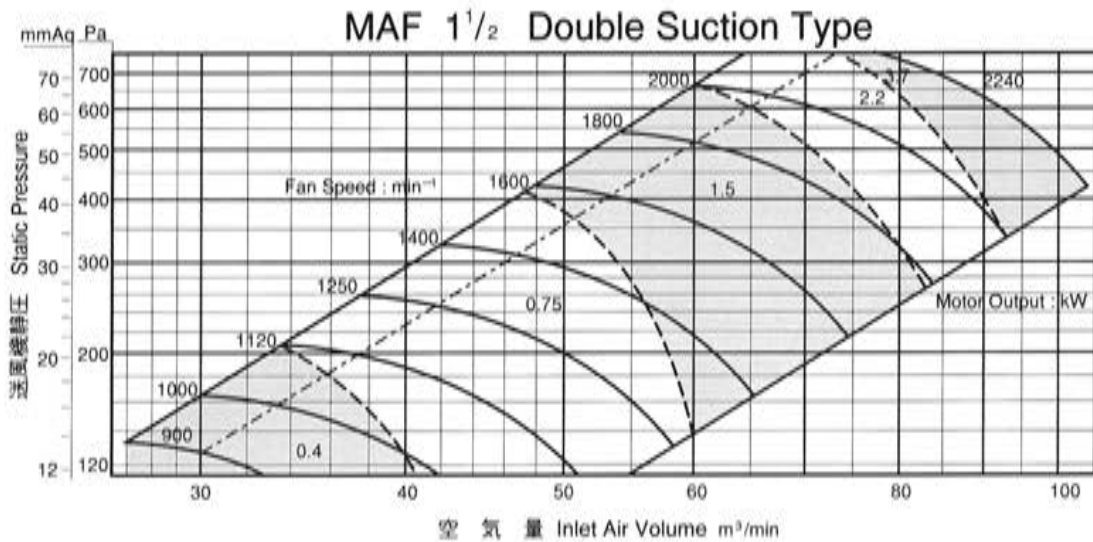
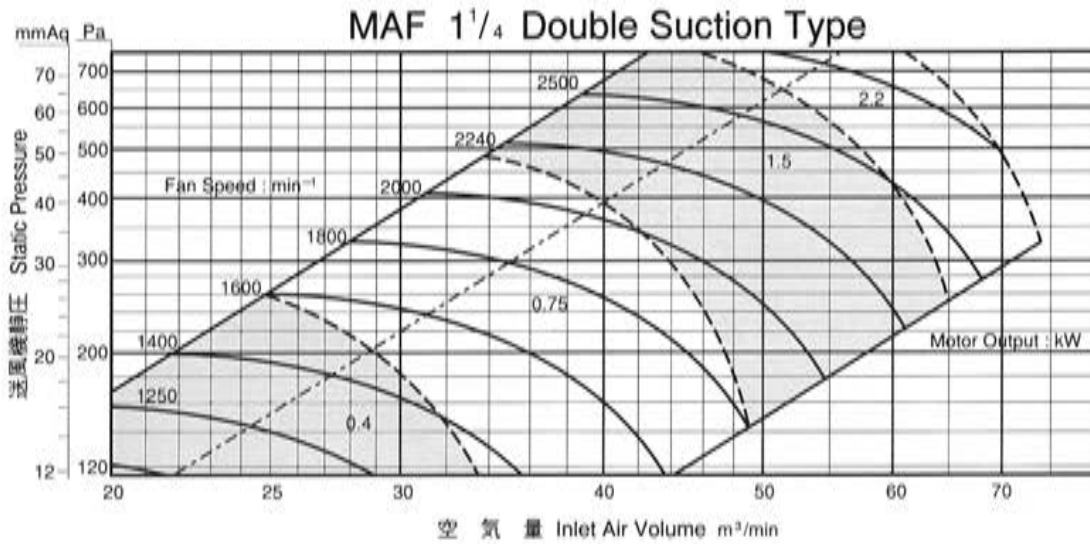
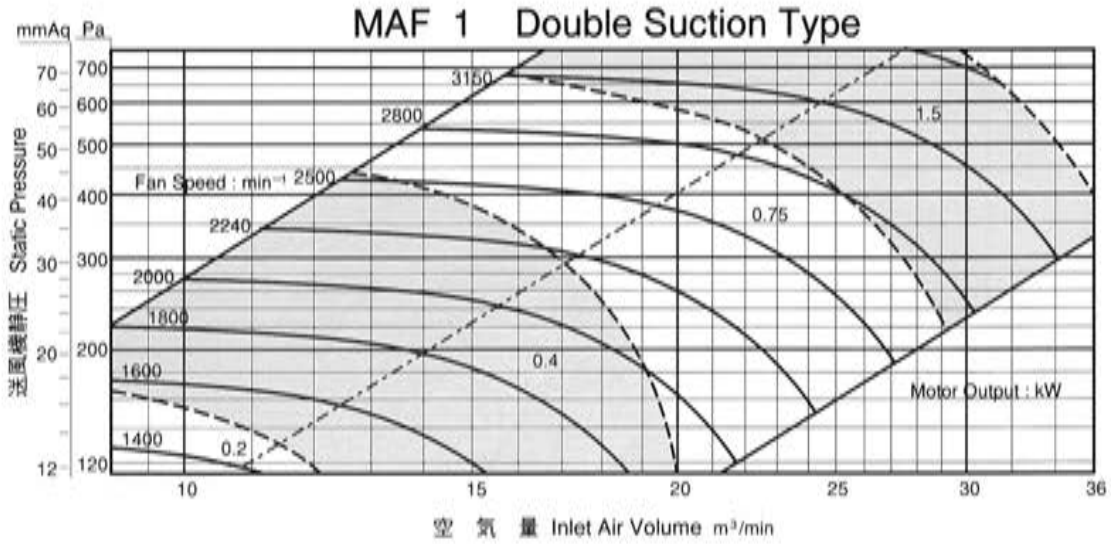

両吸込式容量図 DOUBLE SUCTION TYPE CAPACITY CHART

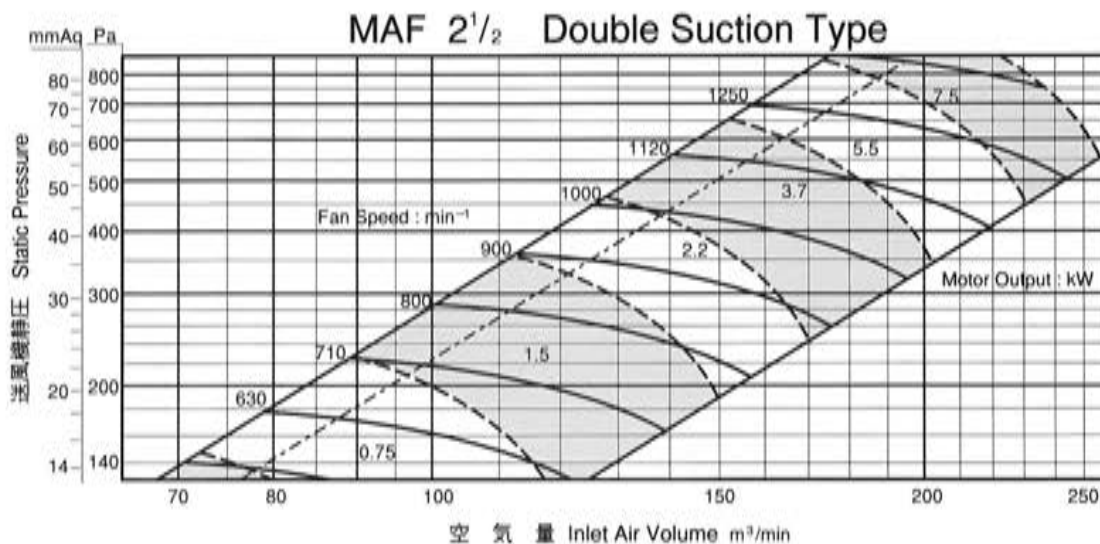
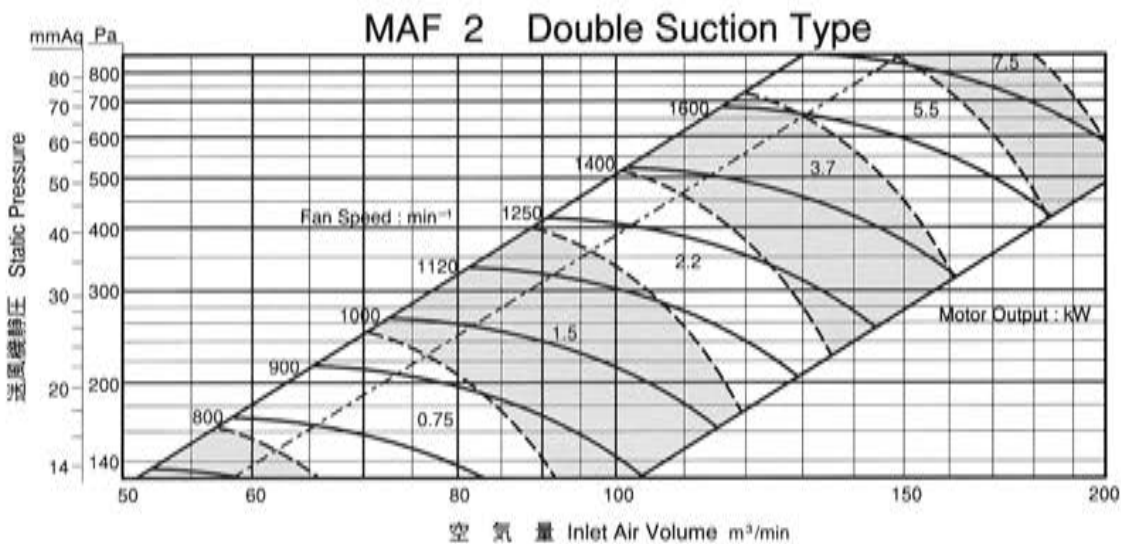
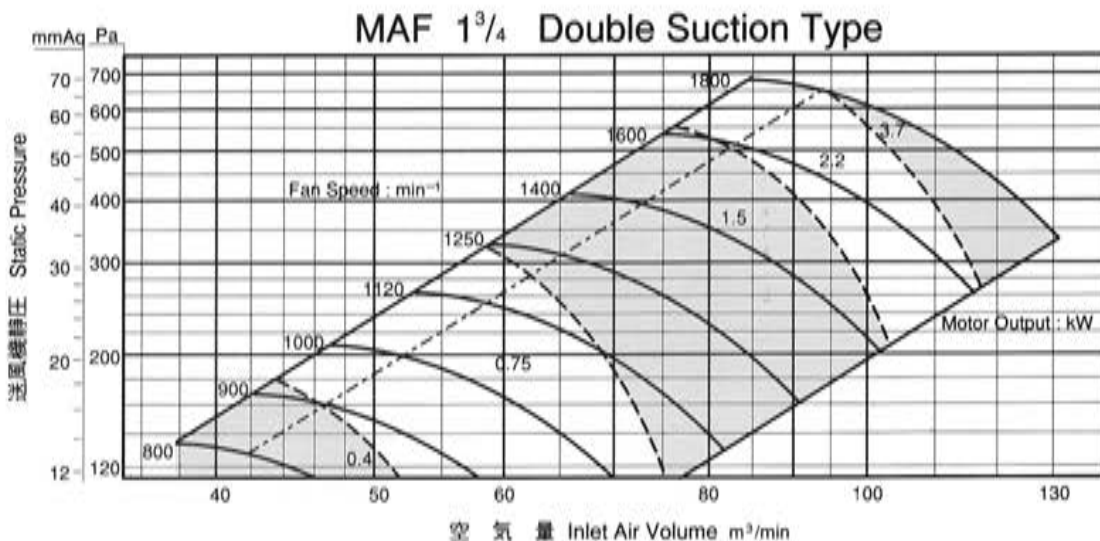

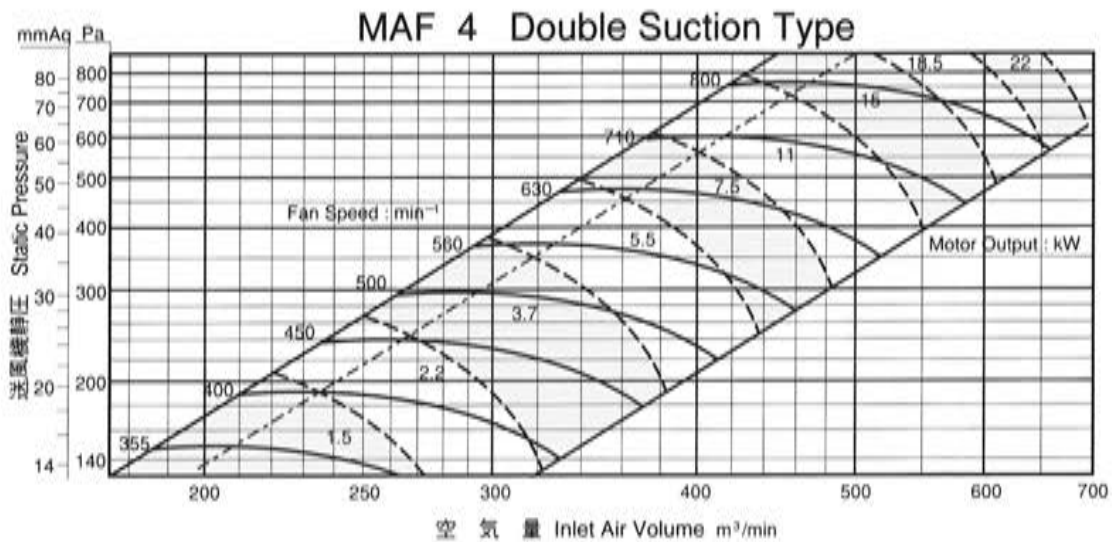
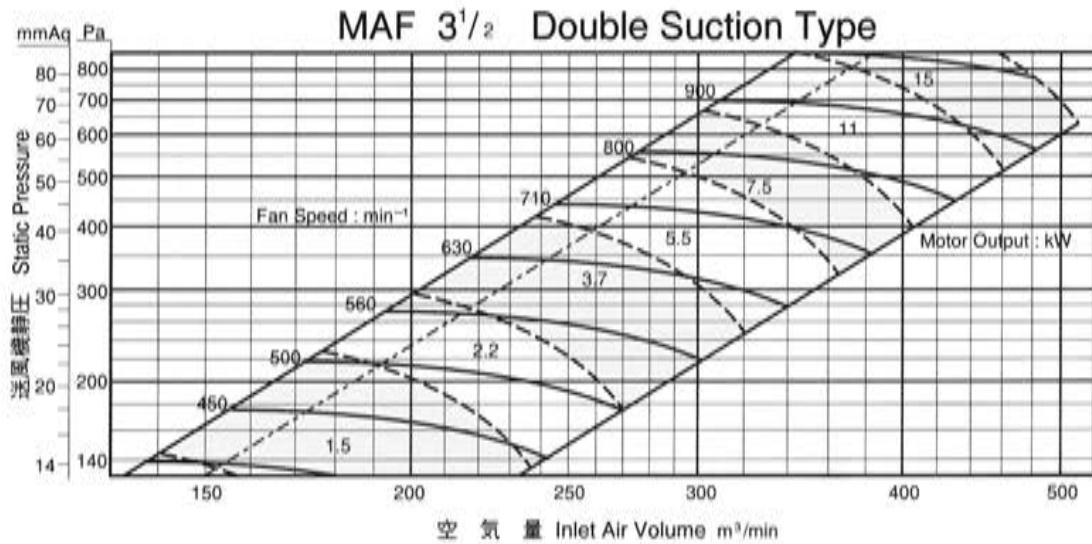
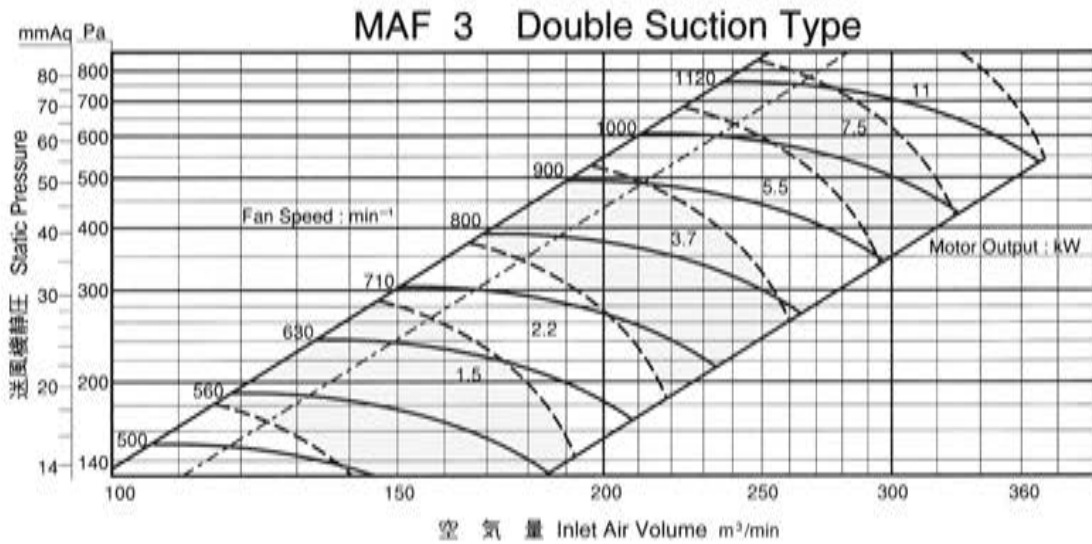

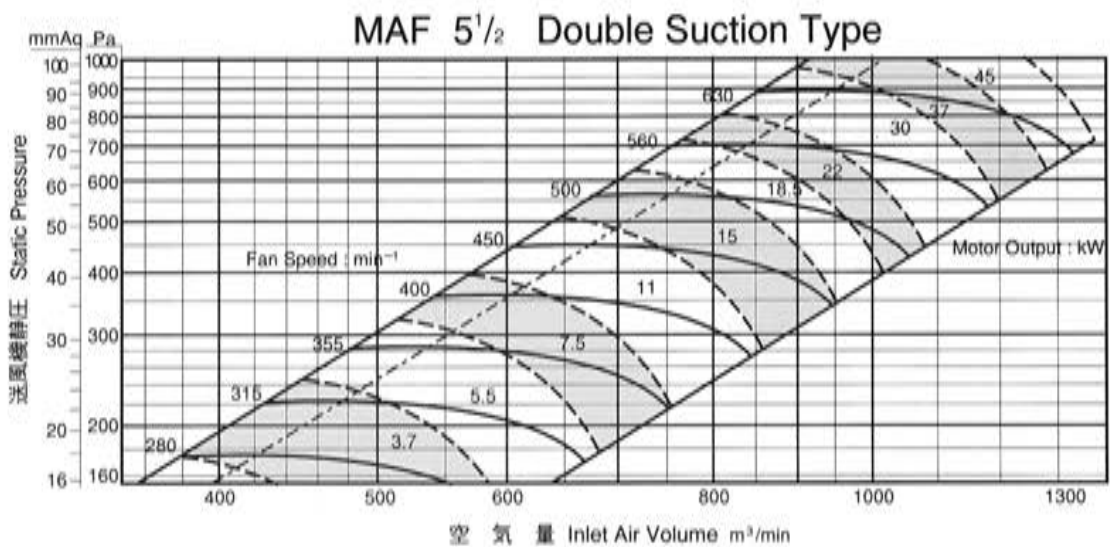
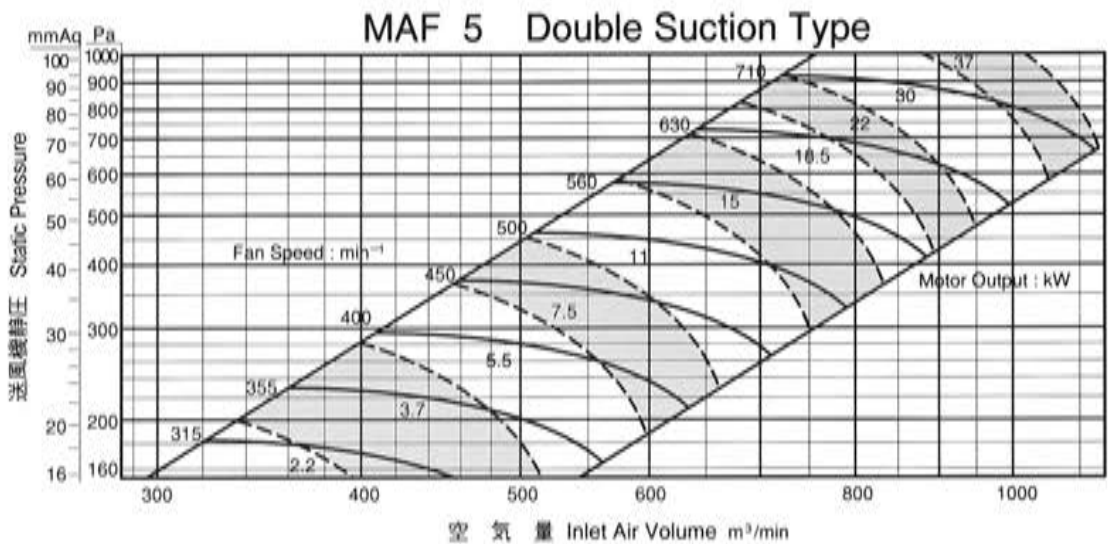
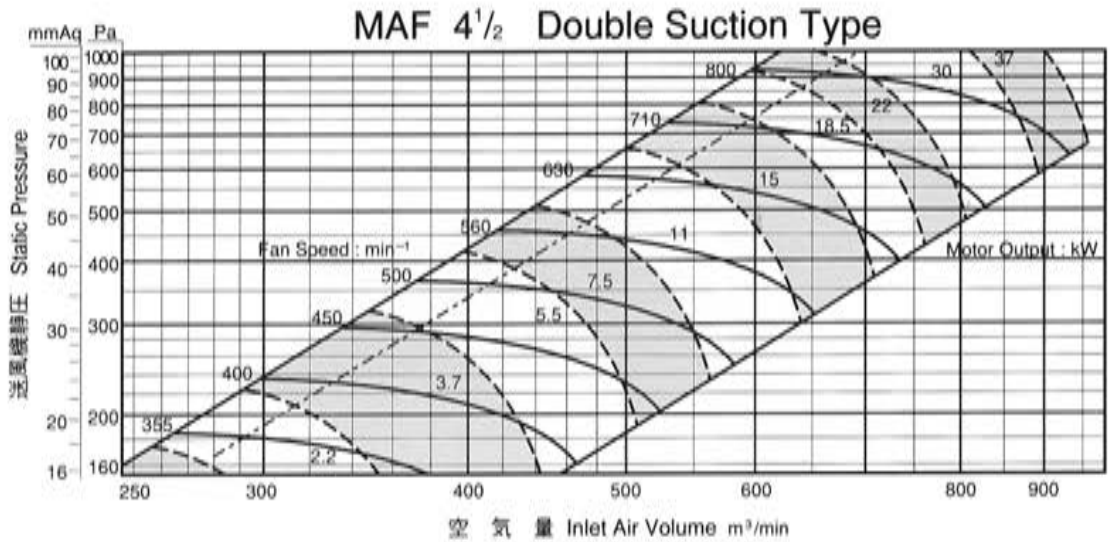

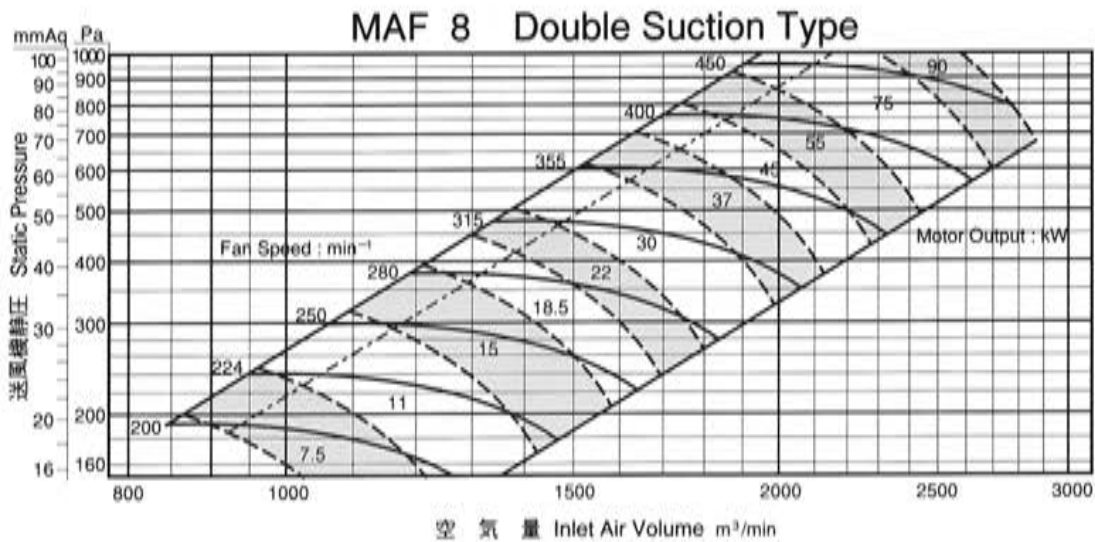
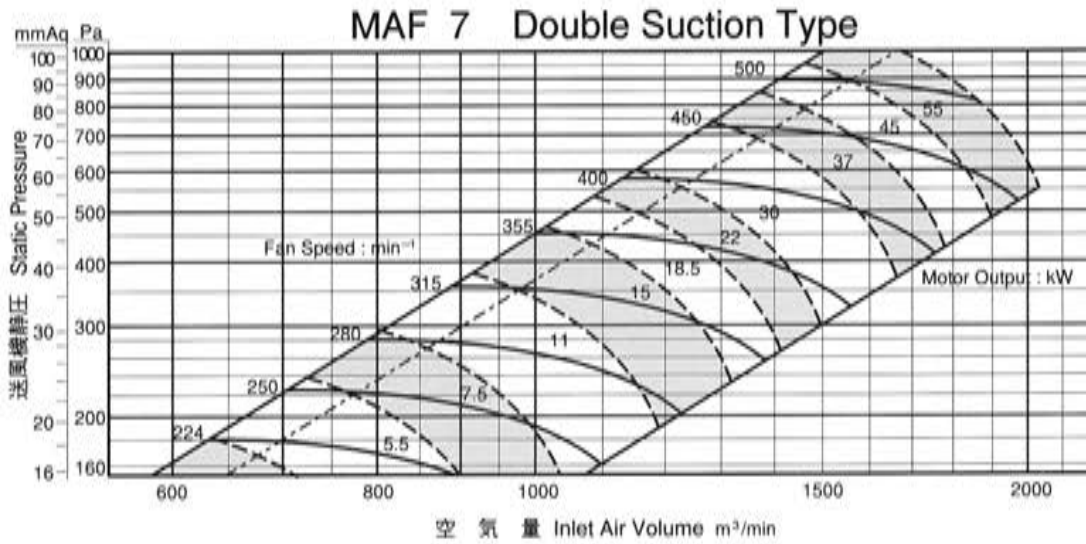
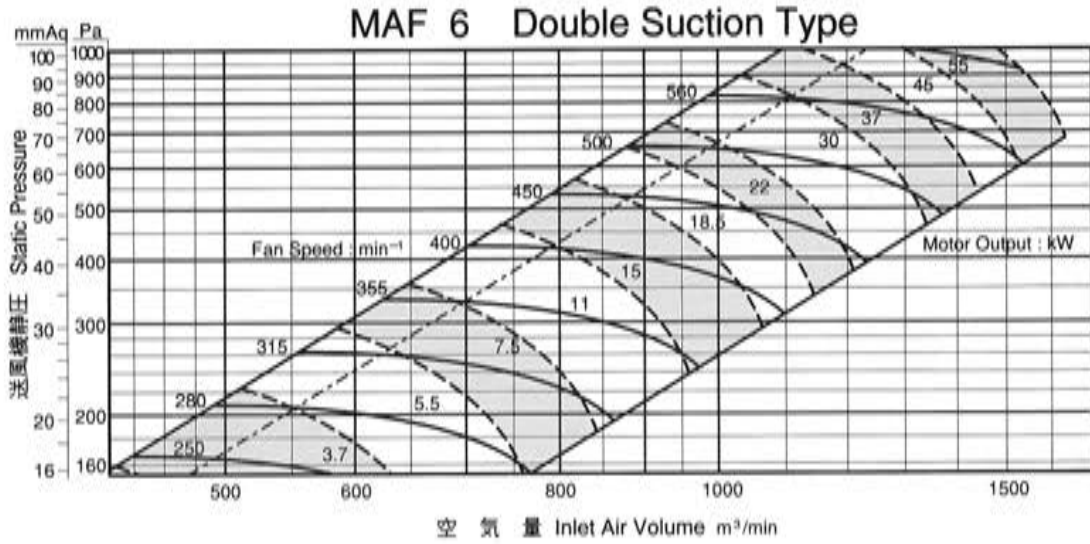

両吸込式容量図 DOUBLE SUCTION TYPE CAPACITY CHART

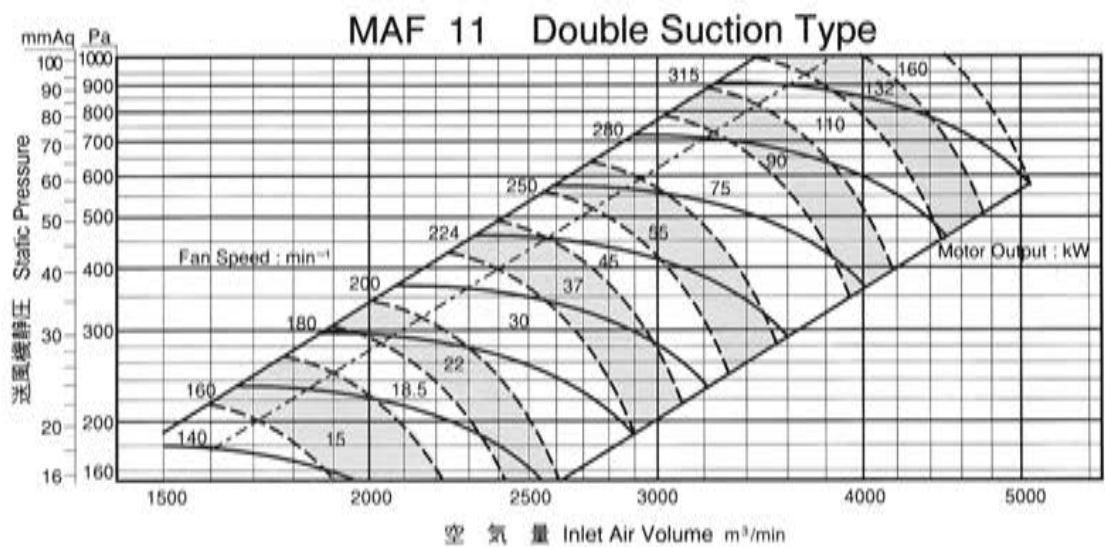
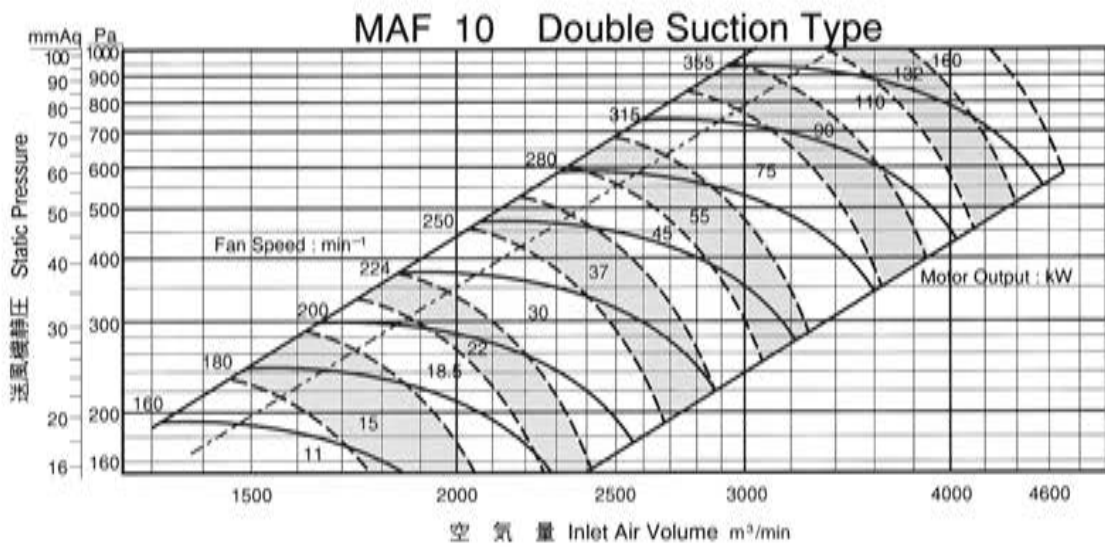
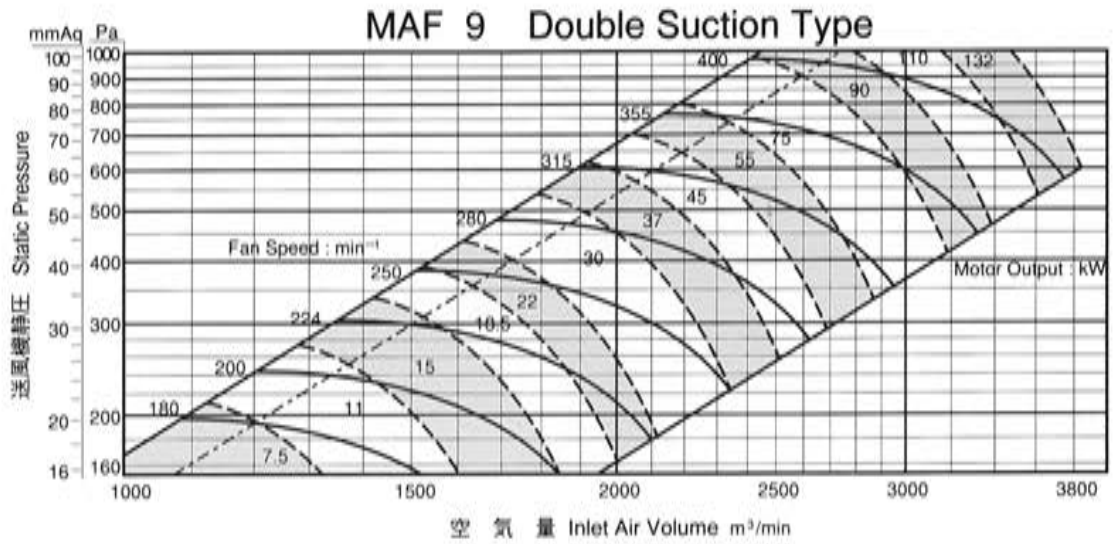

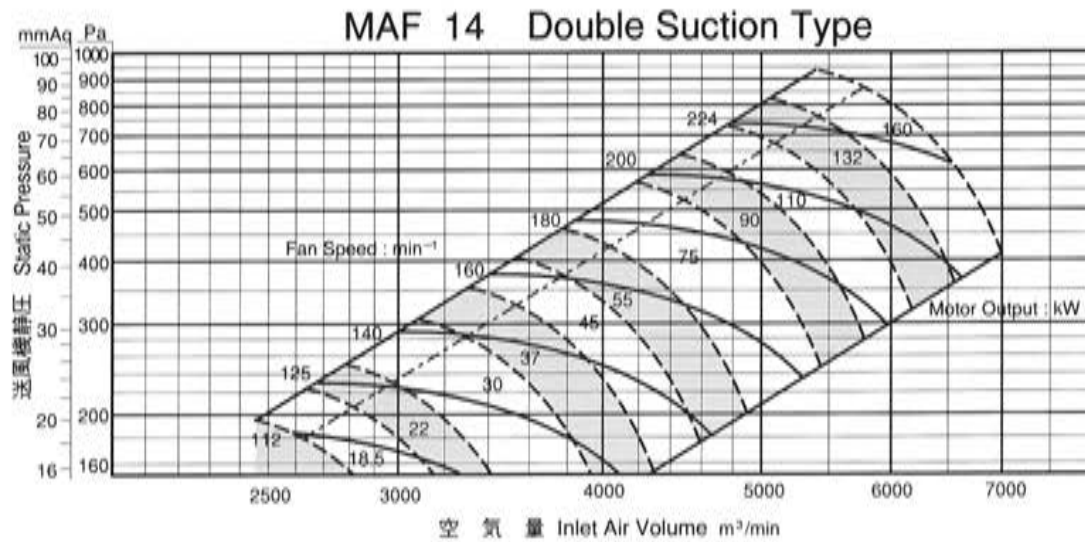
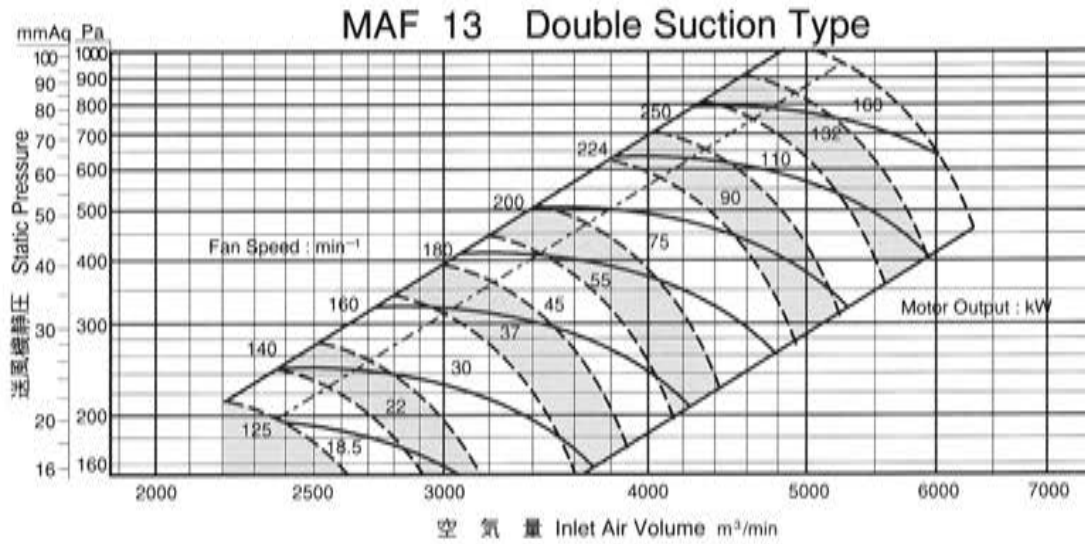
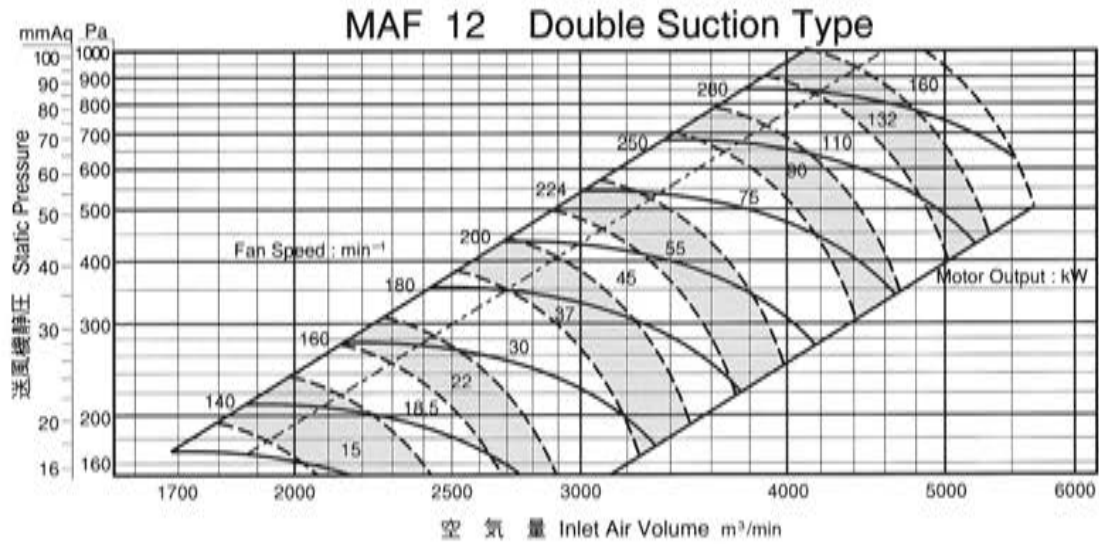

MAF 15 Double Suction Type

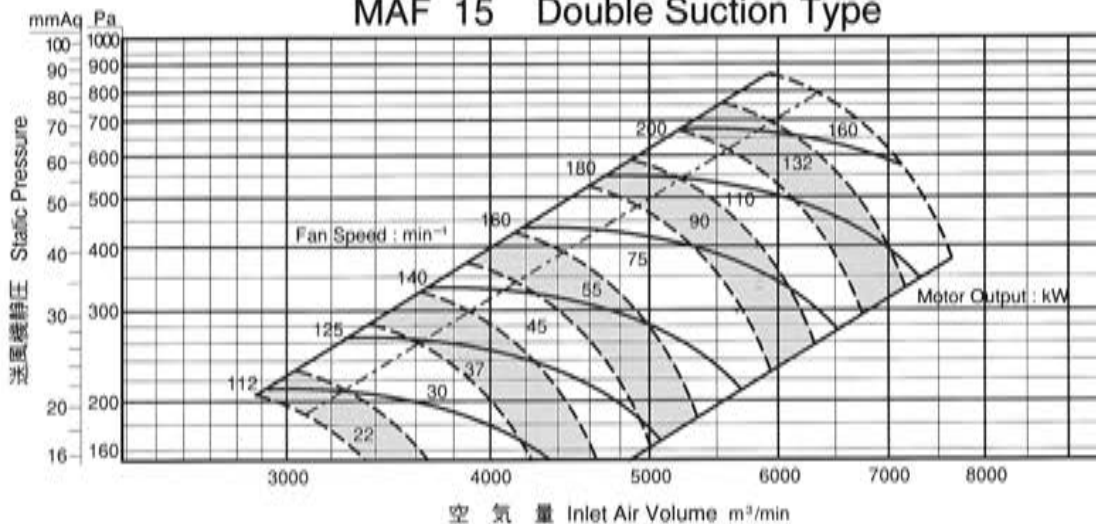

MAF 16 Double Suction Type

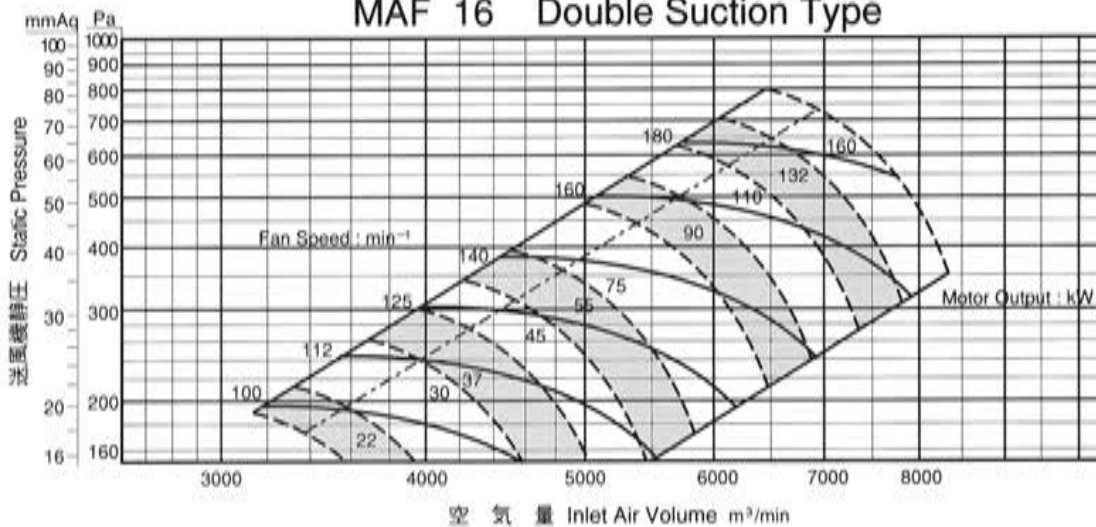

MAF 18 Double Suction Type

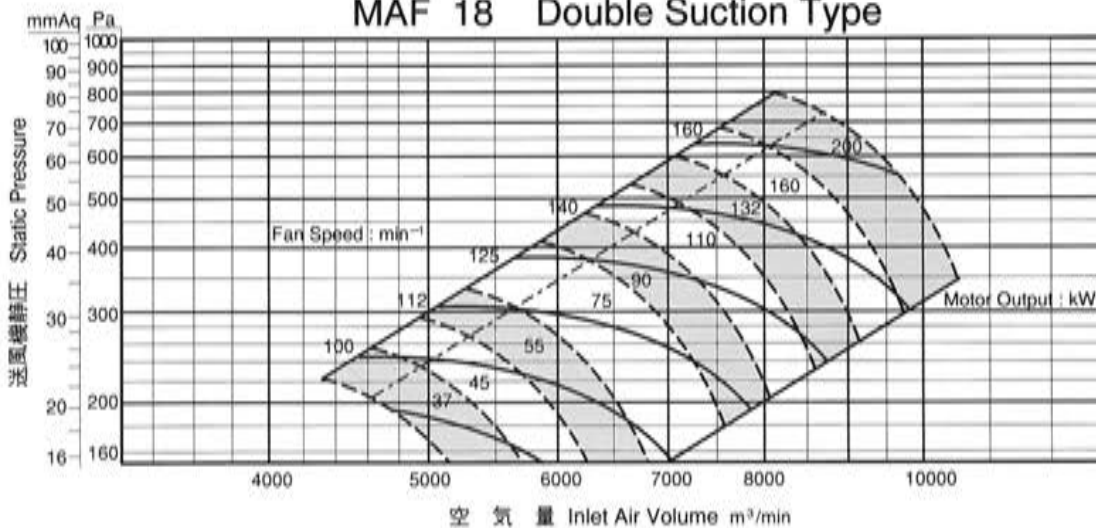

片吸込式 S1形 寸法表 SINGLE SUCTION S1 TYPE DIMENSIONS

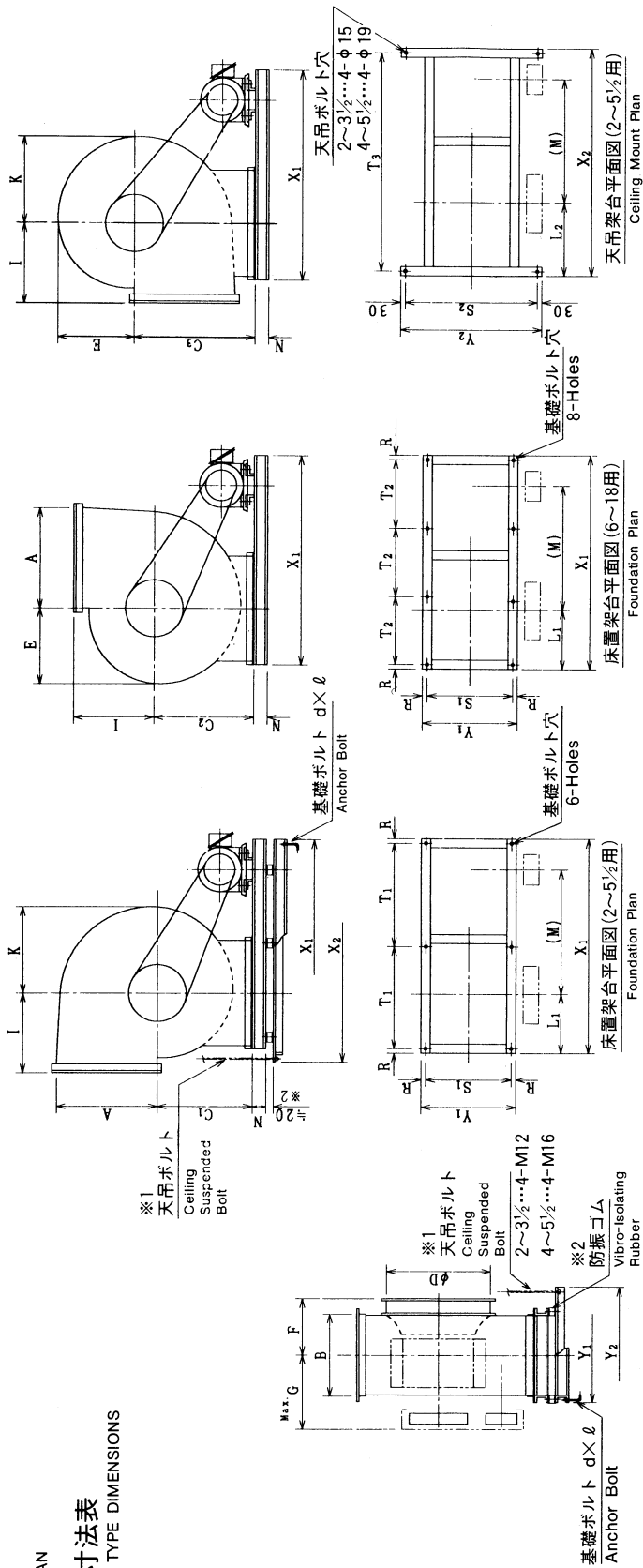

呼び番号 Fan Size	ケーシング Casing													芯高 Center Height				共通基台・防振基台 Common Base-Vibro-Isolating Base				天吊基台 Ceiling Mount Base				基礎ボルト Anchor Bolt	相フランジ Companion Flange	重量kgf Weight (電動機不含) Without Motor	GD4kgf・m ² (フリーホウ) Without Pulley
	A	B	D	E	F	G	I	K	L	M	N	R	S	T	T ₁	T ₂	X ₁	Y ₁	L ₂	S ₂	T ₂	X ₂	Y ₂	d	ℓ				
2	300	240	335	228	185	300	250	260	310	310	310	375	200	500	75	18	284	407	—	850	320	400	866	910	460	M10	160		
2½	375	300	412	285	225	370	300	325	375	375	375	450	245	625	75	18	344	507	—	1050	380	295	1066	1110	520	M10	160		
3	450	360	500	342	255	420	350	390	450	450	450	530	290	680	100	22	416	578	—	1200	460	355	1222	1280	600	M12	200		
3½	525	420	580	399	300	490	400	455	510	510	630	335	380	785	100	22	476	668	—	1380	520	400	1402	1460	660	M12	200		
4	600	480	670	456	330	520	450	520	530	580	710	380	495	925	100	22	536	753	—	1550	580	445	1572	1630	720	M12	200		
4½	675	540	750	513	360	570	510	585	600	660	800	495	540	980	100	22	612	838	—	1720	656	510	1692	1750	820	M12	200		
5	750	600	825	570	390	640	640	660	650	730	900	540	540	1080	100	22	672	888	—	1820	716	555	1792	1850	880	M12	200		
5½	825	660	900	627	420	700	680	715	710	800	950	585	585	1045	100	22	732	943	—	1930	776	600	1902	1960	940	M12	200		
6	900	720	1000	684	480	790	790	800	780	850	1060	630	630	1180	125	29	792	—	684	2110	850	—	—	—	—	M16	250		
7	1050	840	1150	798	540	850	800	810	880	1000	1180	720	720	1270	125	29	912	—	744	2290	970	—	—	—	—	M16	250		
8	1200	960	1320	912	620	910	900	1040	1000	1120	1320	820	820	1420	125	29	1044	—	844	2590	1102	—	—	—	—	M16	250		
9	1350	1080	1500	1026	710	990	1000	1170	1120	1250	1500	910	910	1540	150	33	1164	—	928	2850	1230	—	—	—	—	M20	315		
10	1500	1200	1650	1140	775	1050	1100	1300	1250	1400	1650	990	990	1640	150	33	1310	—	988	3030	1376	—	—	—	—	M20	315		
11	1650	1320	1820	1254	855	1130	1200	1430	1350	1520	1800	1090	1090	1890	200	40	1430	—	1100	3380	1510	—	—	—	—	M24	400		
12	1800	1440	1980	1368	925	1190	1300	1560	1450	1650	1950	1180	1180	1980	200	40	1550	—	1160	3560	1630	—	—	—	—	M24	400		
13	1950	1560	2140	1482	1015	1250	1400	1690	1580	1780	2120	1255	1255	2125	200	40	1696	—	1250	3830	1776	—	—	—	—	M24	400		
14	2100	1680	2310	1596	1075	1350	1500	1820	1680	1920	2300	1345	1345	2215	200	40	1816	—	1310	4010	1896	—	—	—	—	M24	400		
15	2250	1800	2480	1710	1155	1430	1600	1950	1800	2060	2430	1450	1450	2290	250	40	1936	—	1370	4190	2016	—	—	—	—	M30	500		
16	2400	1920	2640	1824	1225	1490	1700	2080	1920	2170	2600	1540	1540	2440	250	40	2056	—	1450	4430	2136	—	—	—	—	M30	500		
17	2550	2040	2800	1938	1295	1570	1800	2210	2060	2330	2720	1650	1650	2480	250	40	2200	—	1500	4580	2280	—	—	—	—	M30	500		
18	2700	2160	2970	2052	1375	1630	1900	2340	2180	2460	2900	1750	1750	2560	250	40	2320	—	1570	4760	2400	—	—	—	—	M30	500		

注 ※1. 天吊形の場合、天吊ボルトは貴社にてご用意下さい。

Ceiling-suspended bolts are not supplied.

※2. 防振ゴムの代わりにバネを使用の際は高さは≒100になります。

When springs are used in place of vibro-isolating rubbers the height is approx 100.

3. ()寸法は参考寸法です。
Dimensions with () mark are subject to change.

(Unit : mm)

MAF 多翼送風機
MAF MULTIBLADE FAN

片吸込式 S2形 S2-H形 寸法表
SINGLE SUCTION S2, S2-H TYPE DIMENSIONS

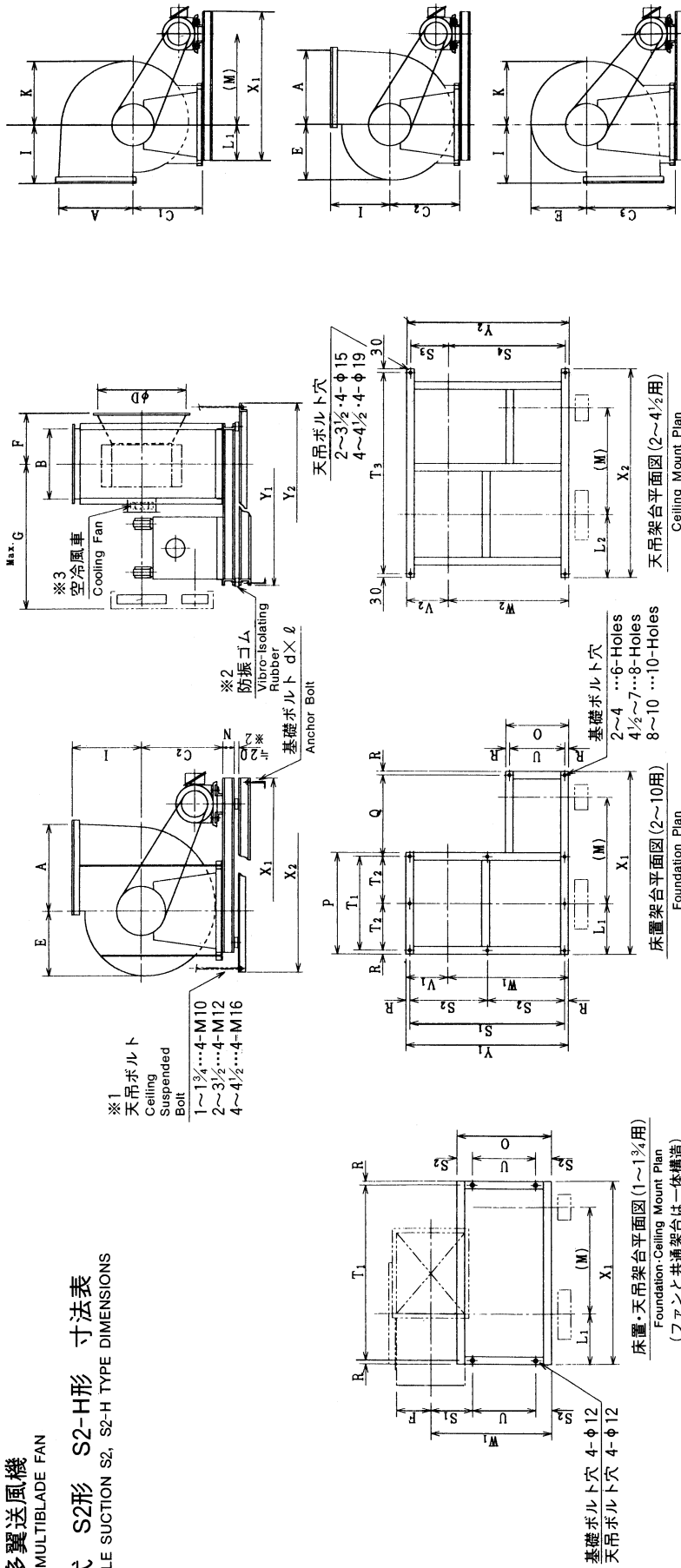

呼び番号 Fan Size	ケーシング Casing										芯高 Center Height										共通基台・防振基台 Common Base・Vibro-Isolating Base										天吊基台 Ceiling Mount Base										基礎ボルト Anchor Bolt	相フランジ Companion Flange	重量kgf Weight (電動機不含) Without Motor	GDkgf・m ² (プーリ不含) Without Pulley					
	A	B	D	E	F	G	I	K	C ₁	C ₂	C ₃	L ₁	L ₂	L ₃	M	N	O	P	Q	R	S ₁	S ₂	S ₃	T ₁	T ₂	T ₃	U	V ₁	V ₂	W ₁	W ₂	W ₃	X ₁	X ₂	Y ₁	Y ₂	d	f											
1	150	120	165	114	60	490	155	130	230	230	165	440	40	390	—	—	—	—	—	—	18	100	80	734	—	—	—	—	—	—	—	—	—	—	—	—	—	—	—	M10	160	L-25×25×3	40	0.02					
1 ¼	190	150	203	143	75	510	155	163	230	230	165	440	40	390	—	—	—	—	—	—	18	115	80	734	—	—	—	—	—	—	—	—	—	—	—	—	—	—	—	M10	160	L-25×25×3	43	0.04					
1 ½	228	180	242	171	90	520	180	195	230	230	165	440	40	390	—	—	—	—	—	—	18	130	80	734	—	—	—	—	—	—	—	—	—	—	—	—	—	—	—	M10	160	L-25×25×3	46	0.09					
1 ¾	268	210	284	200	105	540	210	228	230	230	165	440	40	390	—	—	—	—	—	—	18	145	80	734	—	—	—	—	—	—	—	—	—	—	—	—	—	—	—	—	M10	160	L-25×25×3	50	0.17				
2	300	240	335	228	185	700	250	260	310	310	375	200	370	75	300	400	320	18	724	—	18	174	—	364	—	—	—	—	—	—	—	—	—	—	—	—	—	—	—	M10	160	L-30×30×3	135	0.33					
2 ¼	375	300	412	285	225	770	300	325	375	375	450	245	465	75	300	490	400	18	784	—	18	190	630	890	820	295	230	612	890	252	634	950	886	M10	160	L-30×30×3	165	0.79											
3	450	360	500	342	255	900	350	390	450	450	530	290	580	100	350	580	520	22	906	—	18	210	698	1120	299	727	1180	1026	M12	200	L-30×30×3	240	1.7																
3 ¼	525	420	580	399	300	1020	400	455	510	510	630	335	655	100	400	670	580	22	1056	—	18	264	800	1270	329	847	1330	1176	M12	200	L-30×30×3	310	3.4																
4	600	480	670	455	330	1090	450	520	530	530	600	710	380	700	100	450	760	380	1156	—	18	290	910	1340	1200	445	330	888	1360	359	917	1420	1276	M12	200	L-30×30×3	365	6.4											
4 ¼	675	540	750	513	360	1180	510	585	600	660	800	360	720	100	450	720	660	22	1156	—	18	306	938	1480	409	967	1540	1376	M12	200	L-40×40×3	485	10.5																
5	750	600	825	570	390	1260	560	650	650	730	900	397	763	100	500	794	666	22	1258	—	18	356	1026	1450	456	380	1070	1530	1450	—	—	—	—	—	—	—	—	M12	200	L-40×40×3	610	18.6							
5 ¼	825	660	900	627	420	1330	620	715	710	800	950	435	795	100	500	870	660	22	1330	—	18	406	1120	1595	1650	1620	—	—	—	—	—	—	—	—	—	—	—	—	—	—	M12	200	L-40×40×3	710	31.5				
6	900	720	1000	684	480	1460	680	780	760	850	1060	479	871	125	500	958	692	29	1416	—	18	442	1270	1700	1770	—	—	—	—	—	—	—	—	—	—	—	—	—	—	—	—	M16	250	L-40×40×3	950	54			
7	1050	840	1150	798	540	1550	800	910	880	1000	1180	554	946	125	500	1108	692	29	1512	—	18	482	1385	1800	1930	—	—	—	—	—	—	—	—	—	—	—	—	—	—	—	—	—	M16	250	L-40×40×3	1200	124		
8	1200	960	1320	912	620	1660	900	1040	1000	1120	1320	629	1021	125	500	1258	742	29	1614	—	18	522	1535	2000	1930	—	—	—	—	—	—	—	—	—	—	—	—	—	—	—	—	—	—	M16	250	L-40×40×3	1470	204	
9	1350	1080	1500	1026	710	1835	1000	1170	1120	1250	1500	708	1102	150	630	1416	794	33	1716	—	18	564	1615	2210	2140	—	—	—	—	—	—	—	—	—	—	—	—	—	—	—	—	—	—	M16	250	L-40×40×3	1990	328	
10	1500	1200	1650	1140	775	1995	1100	1300	1250	1400	1650	783	1177	150	630	1566	794	33	1814	—	18	612	1715	2360	2360	—	—	—	—	—	—	—	—	—	—	—	—	—	—	—	—	—	—	—	M16	250	L-40×40×3	2470	603

注 ※1. 天吊形の場合、天吊ボルトは貴社にてご用意下さい。
Ceiling-suspended bolts are not supplied.

※2. 防振ゴムの代わりにバネを使用の際は高さは≒100)になります。
When springs are used in place of vibro-isolating rubbers the height is approx 100.

※3. 空冷風車は、耐熱形 (S2-H) にのみ取り付けます。
High temperature application is installed cooling fan.

4. () 寸法は参考寸法です。
Dimensions with () mark are subject to change.

MAF 多翼送風機
MAF MULTIBLADE FAN
両吸込式 D1形 寸法表
DOUBLE SUCTION D1 TYPE DIMENSIONS

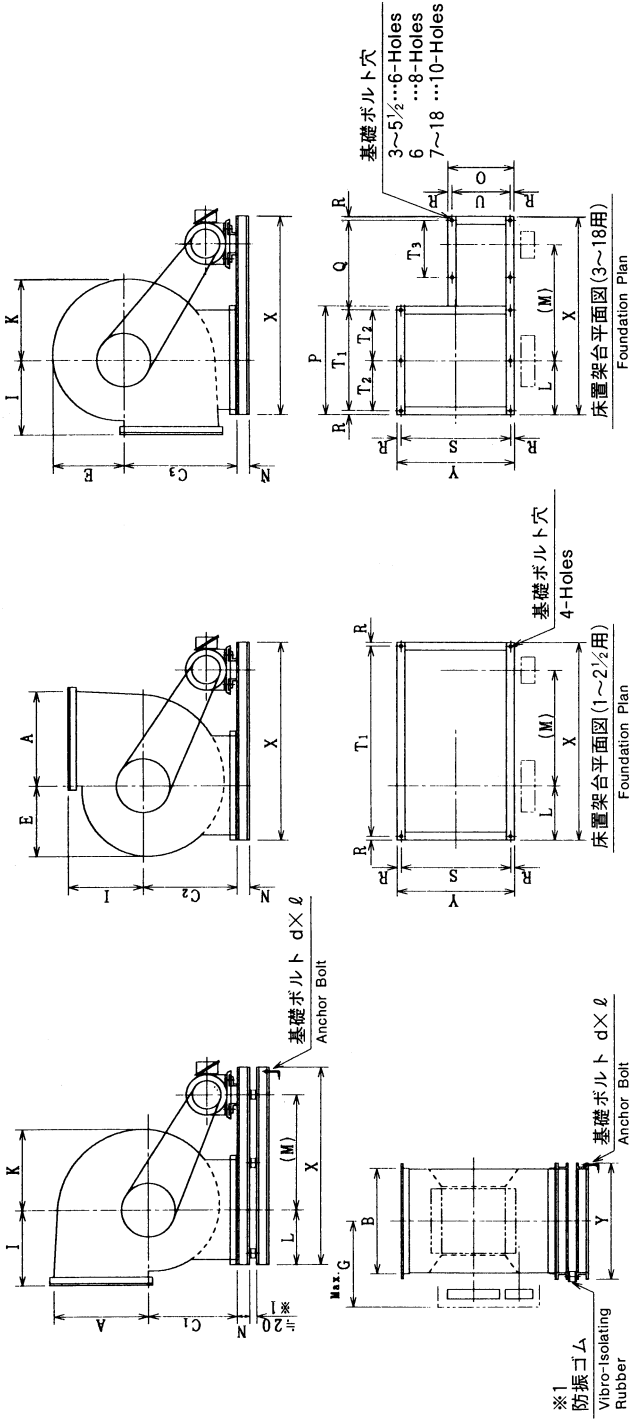

呼び番号 Fan Size	ケーシング Casing					芯高 Center Height			共通架台・防振架台 Common Base-Vibro-isolating Base										基礎ボルト Anchor Bolt		相フランジ Companion Flange	重量kgf Weight (電動機不含) Without Motor	GD ² kgf·m ² (ブール不含) Without Pulley						
	A	B	E	G	I	K	C ₁	C ₂	C ₃	L	(M)	N	O	P	Q	R	S	T ₁	T ₂	T ₃				U	X	Y	d	ℓ	
1	140	250	112	315	155	130	180	180	210	125	305	(40)	—	—	—	18	294	544	—	—	—	—	580	330	M10	160	L-25×25×3	37	0.04
1 ¼	190	280	145	330	155	165	210	210	260	145	355	(40)	—	—	—	18	324	614	—	—	—	—	650	360	M10	160	L-25×25×3	40	0.08
1 ½	228	330	174	355	180	198	240	240	300	165	405	(40)	—	—	—	18	374	684	—	—	—	—	720	410	M10	160	L-25×25×3	52	0.17
1 ¾	268	390	204	385	210	232	280	280	340	185	455	(40)	—	—	—	18	434	784	—	—	—	—	820	470	M10	160	L-25×25×3	58	0.34
2	300	460	228	460	250	260	310	310	375	215	535	(40)	—	—	—	18	504	894	—	—	—	—	930	540	M10	160	L-30×30×3	105	0.66
2 ½	375	570	285	560	300	325	375	375	450	245	615	(40)	—	—	—	18	614	1004	—	—	—	—	1040	650	M10	160	L-30×30×3	140	1.7
3	450	690	342	640	350	390	450	450	530	290	660	100	350	580	630	22	746	536	—	—	—	—	306	1210	M12	200	L-30×30×3	245	3.4
3 ½	525	800	399	700	400	455	510	510	630	335	725	100	400	670	650	22	856	626	—	—	—	—	356	1370	M12	200	L-30×30×3	295	6.7
4	600	920	456	800	450	520	530	580	710	380	790	100	400	760	710	22	976	716	—	—	—	—	356	1470	M12	200	L-30×30×3	365	12.7
4 ½	675	1030	513	860	510	585	600	660	800	495	855	100	450	990	660	22	1102	946	—	—	—	—	406	1650	M12	250	L-40×40×3	525	21.1
5	750	1150	570	920	560	650	650	730	900	540	920	125	500	1080	680	29	1222	1022	—	—	—	—	442	1760	M16	250	L-40×40×3	690	37.7
5 ½	825	1220	627	1000	620	715	710	800	950	585	965	125	500	1170	680	29	1292	1112	—	—	—	—	442	1850	M16	250	L-40×40×3	815	64
6	900	1380	684	1090	680	780	760	850	1060	630	1160	125	500	1260	880	29	1452	—	—	—	—	—	442	2140	M16	250	L-40×40×3	1000	95
7	1050	1610	798	1240	800	910	880	1000	1180	720	1250	150	560	1440	880	33	1694	—	—	—	—	—	494	2320	M20	315	L-40×40×3	1450	207
8	1200	1840	912	1360	900	1040	1000	1120	1320	820	1340	150	630	1640	920	33	1950	—	—	—	—	—	564	2560	M20	315	L-40×40×3	1900	340
9	1350	2070	1026	1500	1000	1170	1120	1250	1500	910	1490	150	700	1820	980	33	2180	—	—	—	—	—	634	2800	M20	315	L-40×40×3	2400	551
10	1500	2300	1140	1620	1100	1300	1250	1400	1650	990	1640	150	700	1980	1100	33	2410	—	—	—	—	—	650	3080	M20	315	L-40×40×3	3060	1030
11	1650	2376	1254	1680	1200	1430	1350	1520	1800	1090	1780	200	750	2180	1140	40	2486	—	—	—	—	—	670	3320	M24	400	L-50×50×4	3940	1530
12	1800	2592	1368	1830	1300	1560	1450	1650	1950	1180	1870	200	750	2360	1140	40	2728	—	—	—	—	—	670	3500	M24	400	L-50×50×4	4670	2140
13	1950	2808	1482	1950	1400	1690	1580	1780	2120	1255	1945	200	750	2510	1140	40	2944	—	—	—	—	—	670	3650	M24	400	L-50×50×4	5490	3020
14	2100	3024	1596	2060	1500	1820	1680	1920	2300	1345	2035	250	750	2690	1140	40	3184	—	—	—	—	—	670	3830	M30	500	L-50×50×4	6920	4040
15	2250	3240	1710	2190	1600	1950	1800	2060	2430	1450	2140	250	800	2900	1140	40	3400	—	—	—	—	—	670	4040	M30	500	L-50×50×4	7600	5380
16	2400	3456	1824	2300	1700	2080	1920	2170	2600	1540	2230	250	800	3080	1140	40	3616	—	—	—	—	—	670	4220	M30	500	L-50×50×4	8890	8750

注 ※1. 防振ゴムの代わりにパネを使用の際は高さは100になります。
When springs are used in place of vibro-isolating rubbers the height is approx 100.
2. () 寸法は参考寸法です。
Dimensions with () mark are subject to change.

(Unit : mm)

MAF スリープ付多翼送風機
MAF MULTIBLADE FAN WITH INLET BOXES
両吸込式 D1-S形 寸法表
DOUBLE SUCTION D1-S TYPE DIMENSIONS

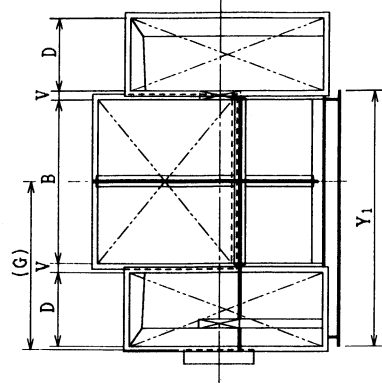
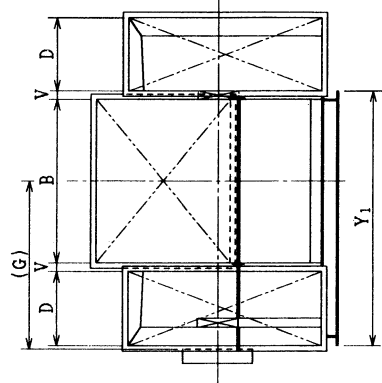
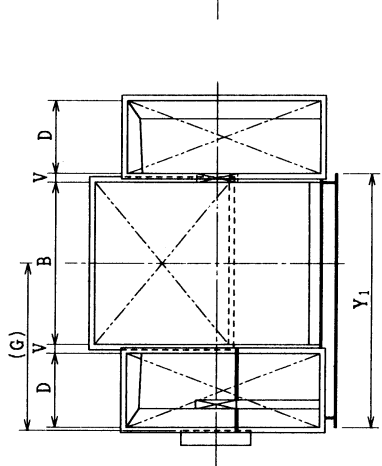
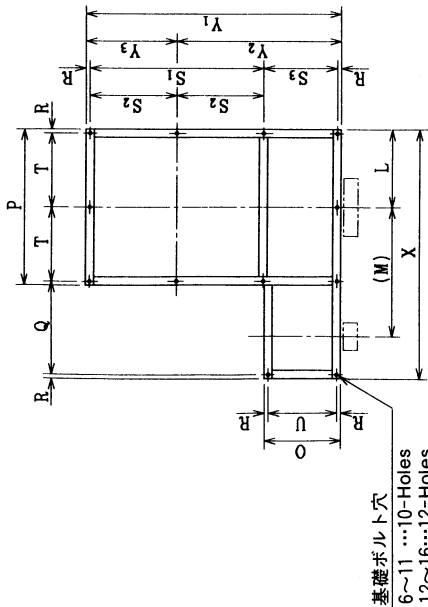
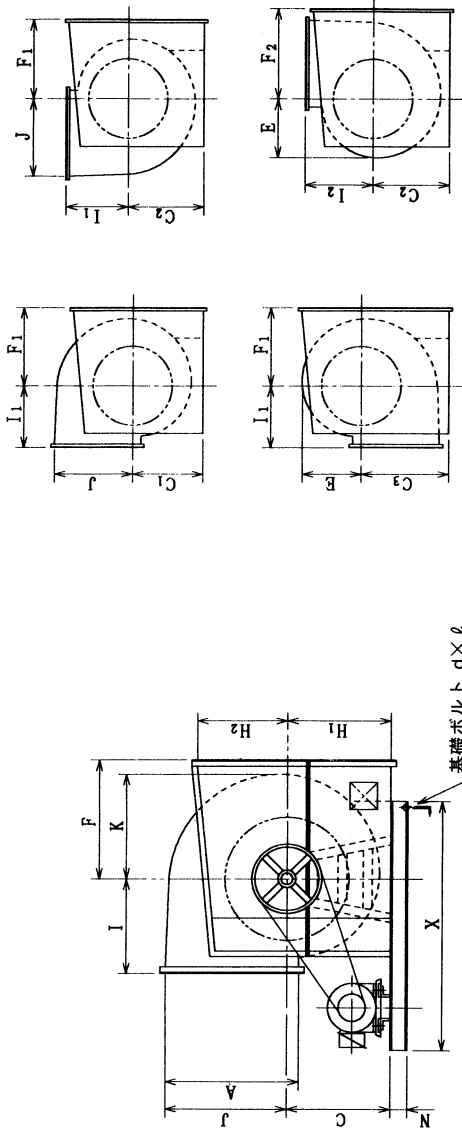

呼び番号 Fan Size	ケーシング Casing																芯高 Center Height			共通架台 Common Base																スリーブ Inlet Box						基礎ボルト Anchor Bolt	相フランジ Companion Flange	GD ^{kgf} ・m ² (フリーホウ)
	A	B	E	G	J	K	I ₁	I ₂	V	C ₁	C ₂	C ₃	L	(M)	N	O	P	Q	R	S ₁	S ₂	S ₃	T	U	X	Y ₁	Y ₂	Y ₃	D	F ₁	F ₂	H ₁	H ₂	d	ℓ									
6	990	1200	684	1285	900	780	840	65	760	850	1060	600	950	125	560	1200	660	29	1272	—	600	571	502	1860	1930	1265	665	600	880	1000	C	720	M16	250	L-40×40×3	95								
7	1155	1400	798	1495	1050	910	800	75	880	1000	1180	700	1070	150	630	1400	700	33	1484	—	700	667	564	2100	2250	1475	775	700	1010	1150	C	840	M20	315	L-40×40×3	207								
8	1320	1600	912	1730	1200	1040	900	1090	100	1000	1120	1320	770	1190	150	630	1540	800	33	1710	—	812	737	564	2340	2588	1700	888	800	1140	1300	C	960	M20	315	L-40×40×3	340							
9	1485	1800	1026	1930	1350	1170	1000	1210	100	1120	1250	1500	860	1280	150	710	1720	800	33	1910	—	912	827	644	2520	2888	1900	988	900	1320	1500	C	1080	M20	315	L-40×40×3	551							
10	1650	2000	1140	2130	1500	1300	1100	1330	100	1250	1400	1650	950	1430	150	710	1900	900	33	2110	—	1012	917	644	2800	3188	2100	1088	1000	1450	1650	C	1200	M20	315	L-40×40×3	1030							
11	1815	2200	1254	2365	1650	1430	1200	1450	125	1350	1520	1800	1060	1580	200	800	2120	1000	40	2336	—	1117	1020	720	3120	3533	2325	1208	1100	1590	1810	C	1320	M24	400	L-50×50×4	1530							
12	1980	2400	1368	2565	1800	1560	1300	1570	125	1450	1650	1950	1150	1670	200	800	2300	1000	40	—	1268	1217	1110	720	3300	3833	2525	1308	1200	1720	1960	C	1440	M24	400	L-50×50×4	2140							
13	2145	2600	1482	2800	1950	1690	1400	1700	150	1580	1780	2120	1250	1770	200	800	2500	1000	40	—	1380	1330	1210	720	3500	4170	2750	1420	1300	1860	2120	C	1560	M24	400	L-50×50×4	3020							
14	2310	2800	1596	3000	2100	1820	1500	1820	150	1680	1920	2300	1340	1860	250	800	2680	1000	40	—	1480	1430	1300	720	3680	4470	2950	1520	1400	1990	2270	C	1680	M30	500	L-50×50×4	4040							
15	2475	3000	1710	3200	2250	1950	1600	1940	150	1800	2060	2430	1430	1950	250	800	2860	1000	40	—	1580	1530	1390	720	3860	4770	3150	1620	1500	2120	2420	C	1800	M30	500	L-50×50×4	5380							
16	2640	3200	1824	3400	2400	2080	1700	2060	150	1920	2170	2600	1520	2040	250	800	3040	1000	40	—	1680	1630	1480	720	4040	5070	3350	1720	1600	2250	2570	C	1920	M30	500	L-50×50×4	8750							

注 1. 吸込口 H₁ 寸法はファン芯高 C₁、C₂ 又は C₃ と同じになります。
Inlet box H₁ = C₁, C₂ and C₃.
2. () 寸法は参考寸法です。
Dimensions with () mark are subject to change.

MAF スリープ付多翼送風機 MAF MULTIBLADE FAN WITH INLET BOXES

両吸込式 D2-S形 寸法表 DOUBLE SUCTION D2-S TYPE DIMENSIONS

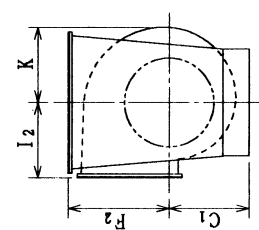
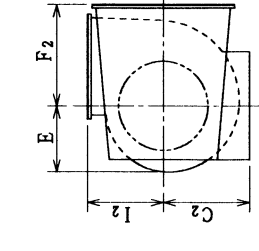
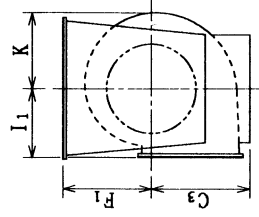
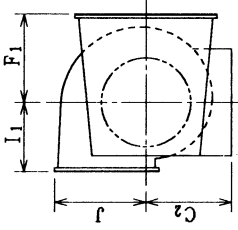
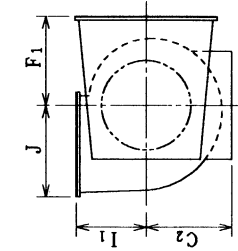
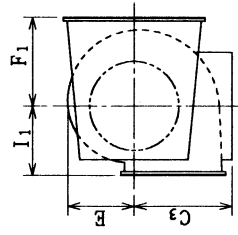
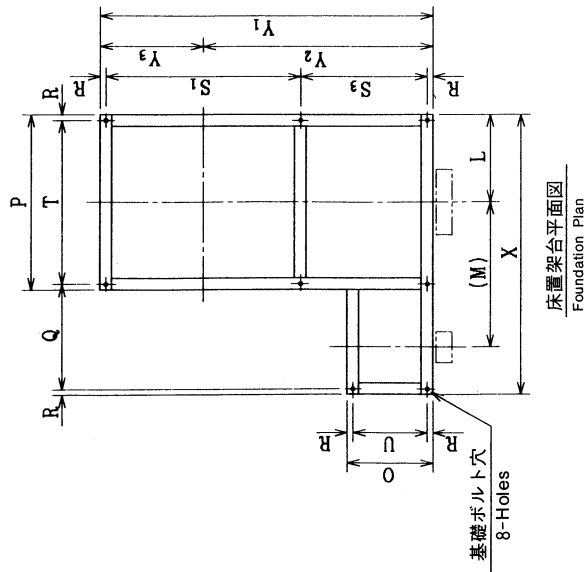
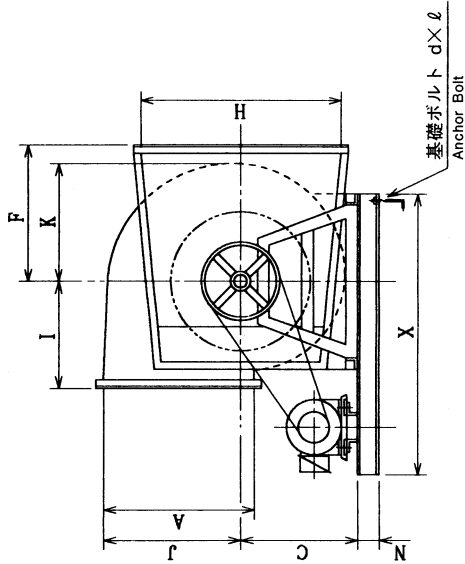
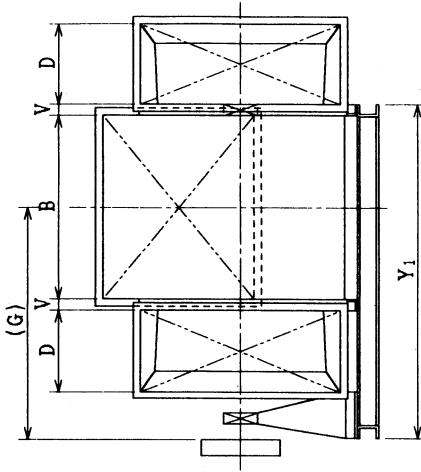

呼び番号 Fan Size	ケーシング Casing								共通 架台 Common Base												スリープ Inlet Box			基礎ボルト Anchor Bolt	相フランジ Companion Flange	GD ² kgf/m ² (フリーホウ)															
	A	B	E	(G)	J	K	I1	I2	V	C1	C2	C3	Center Height	R	Q	P	O	N	M	L	(M)	N	O				P	Q	R	S1	S2	S3	T	U	X	Y1	Y2	Y3	D	F1	F2
3	495	600	342	870	450	390	380	450	50	450	450	530	450	510	510	640	530	400	100	600	600	600	600	640	530	22	656	500	596	356	1170	1200	850	350	300	520	720	M12	200	L-30×30×3	3.4
3 1/2	577	700	399	970	525	455	420	510	50	510	510	630	450	510	510	740	530	450	100	650	650	650	650	740	530	22	756	550	696	406	1270	1350	950	400	350	600	840	M12	200	L-30×30×3	6.7
4	660	800	456	1070	600	520	480	570	50	530	530	710	410	530	530	820	580	450	100	710	710	710	710	820	580	22	856	600	776	406	1400	1500	1050	450	400	680	960	M12	200	L-30×30×3	12.7
4 1/2	742	900	513	1235	675	585	540	660	65	600	660	800	470	770	770	940	580	500	100	770	770	770	770	940	580	22	972	707	896	456	1520	1723	1215	508	450	770	1080	M12	200	L-40×40×3	21.1
5	825	1000	570	1335	750	650	600	720	65	650	730	900	520	870	870	1040	660	560	125	870	870	870	870	1040	660	29	1072	750	982	502	1700	1880	1315	565	500	850	1200	M16	250	L-40×40×3	37.7
5 1/2	908	1100	627	1435	825	715	650	780	65	710	800	950	560	910	910	1120	660	560	125	910	910	910	910	1120	660	29	1172	800	1062	502	1780	2030	1415	615	550	820	1320	M16	250	L-40×40×3	64

注 1. () 寸法は参考寸法です。
Dimensions with () mark are subject to change.

(Unit : mm)

MAF スリープ付多翼送風機
MAF MULTIBLADE FAN WITH INLET BOXES
両吸込式 D3-S形 D3-SH形 寸法表
DOUBLE SUCTION D3-S, D3-SH TYPE DIMENSIONS

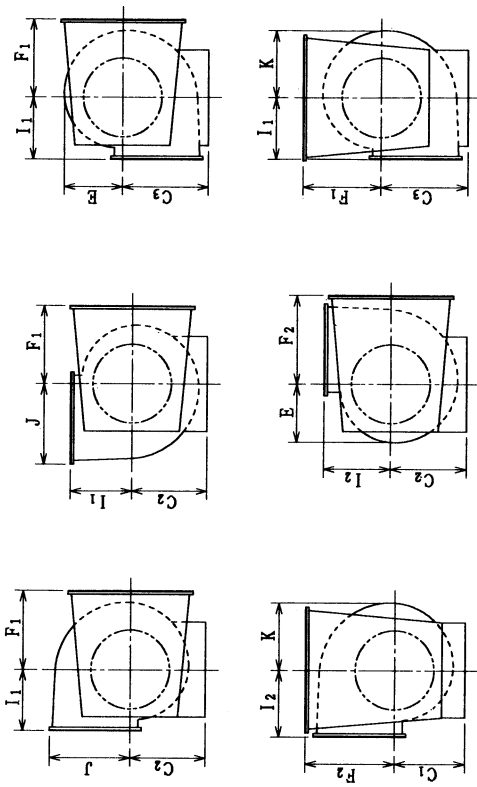
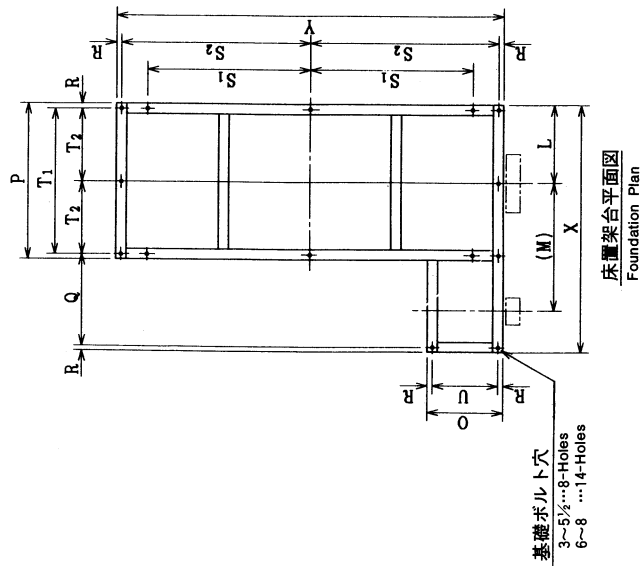
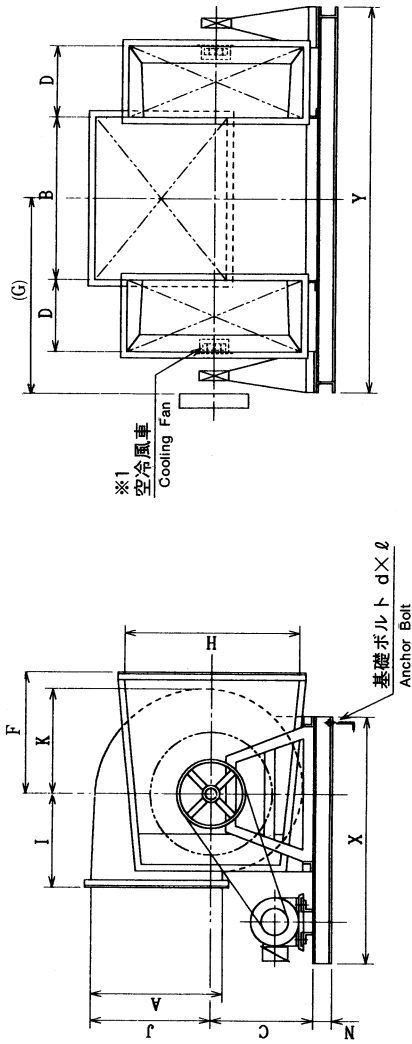

呼び番号 Fan Size	ケーシング Casing										共通架台 Common Base										スリーブ Inlet Box			基礎ボルト Anchor Bolt		相フランジ Companion Flange	GDkgf・m ² (アール不舎) Without Pulley							
	A	B	E	G	J	K	I ₁	I ₂	C ₁	C ₂	C ₃	L	(M)	N	O	P	Q	R	S ₁	S ₂	T ₁	T ₂	U	X	Y			D	F ₁	F ₂	H	d	l	
3	495	600	342	820	450	390	380	450	530	530	320	600	100	400	640	530	22	700	—	—	596	—	356	1170	1600	300	520	520	720	M12	200	L-30×30×3	3.4	
3 1/2	577	700	399	920	525	455	420	510	510	630	370	650	100	450	740	530	22	800	—	—	696	—	406	1270	1800	350	600	600	840	M12	200	L-30×30×3	6.7	
4	660	800	456	1020	600	520	480	570	530	580	410	710	100	450	820	580	22	900	—	—	776	—	406	1400	2000	400	680	680	960	M12	200	L-30×30×3	12.7	
4 1/2	742	900	513	1170	675	585	540	660	600	660	470	770	100	500	940	580	22	1025	—	—	896	—	456	1520	2300	450	770	770	1080	M12	200	L-40×40×3	21.1	
5	825	1000	570	1270	750	650	600	720	650	730	520	870	125	560	1040	660	29	1100	—	—	982	—	502	1700	2500	500	750	850	1200	M16	250	L-40×40×3	37.7	
5 1/2	908	1100	627	1370	825	715	650	780	710	800	560	910	125	560	1120	660	29	1200	—	—	1062	—	502	1780	2700	550	820	920	1320	M16	250	L-40×40×3	64	
6	990	1200	684	1520	900	780	680	840	760	850	600	950	125	560	1200	660	29	1200	1471	—	—	571	502	1860	3000	600	880	1000	1440	M16	250	L-40×40×3	95	
7	1155	1400	798	1720	1050	910	800	970	880	1000	1180	700	150	630	1400	700	33	1400	1667	—	—	667	564	2100	3400	700	1010	1150	1680	M20	315	L-40×40×3	207	
8	1320	1600	912	2020	1200	1040	900	1090	1000	1120	1320	770	1190	150	630	1540	800	33	1600	1967	—	—	737	564	2340	4000	800	1140	1300	1920	M20	315	L-40×40×3	340

注 ※1. 空冷風車は、耐熱形 (D3-SH) へのみ取り付けます。
High temperature application is installed cooling fan.

2. () 寸法は参考寸法です。
Dimensions with () mark are subject to change.

(Unit : mm)



株式会社 タニヤマ

本社・尼崎工場 / 〒660-0834 兵庫県尼崎市北初島町18
TEL (06) 4868-3530 FAX (06) 4868-3672

大阪営業所 / 〒550-0004 大阪市西区鞠本町1丁目11番7号
信濃橋三井ビルディング3階
TEL (06) 6445-3300 FAX (06) 6445-3355

東京営業所 / 〒112-0004 東京都文京区後楽2丁目3番27号
テラル後楽ビル3階
TEL (03) 5805-0558 FAX (03) 5805-0557

TANIYAMA CO.,LTD.

Head Office 18, Kitahatsushimacho, Amagasaki, Hyogo, 660-0834 Japan
Phone: +81-6-4868-3530 Fax: +81-6-4868-3672

Osaka Office Shinanobashimitsui Bldg., 1-11-7, Utsubohonmachi, Nishi-Ku,
Osaka, 550-0004 Japan
Phone: +81-6-6445-3300 Fax: +81-6-6445-3355

Tokyo Office TERAL Koraku Bldg., 2-3-27, Koraku, Bunkyo-Ku,
Tokyo, 112-0004 Japan
Phone: +81-3-5805-0558 Fax: +81-3-5805-0557